

aerospace
SOLUTIONS

www.alliedmachine.com

**TAKING
FLIGHT:**

*solutions to take your
production off the ground*



VS



Master difficult materials



Improve productivity



Benefit from innovative solutions



PCD: Polycrystalline Diamond
The drill insert you've been looking for.





aerospace **SOLUTIONS**

CONTENTS

Specialized Tooling

GEN3SYS® XT Vacuum Drill	2
T-A® PCD Drill Insert	3

Component Solutions

Central Fuselage	4
Valve Actuator	5
Landing Gear	6-7
Engine Manifolds	8
Hydraulic Manifolds	9
Impeller	10
Propeller Engine	11
Rod Ends and Wing Hinges	12
Components and Fasteners	13

ORDERING

The solutions listed in this guide represent general standard products and/or special product designs. To order items specific to your application, please contact your local Allied Field Sales Engineer or a member of Allied's Application Engineering Team.

Application Engineering Department
1.330.343.4283 ext.7611
appeng@alliedmachine.com



ALLIED MACHINE & ENGINEERING

Holemaking Solutions for Today's Manufacturing



The GEN3SYS XT Vacuum Drill allows you to reap the productivity benefits of the GEN3SYS XT outside of a fixed-position machine tool. The Vacuum Drill technology attaches to a hose to remove material that flows up through the internal flute of the drill. This versatile ability allows the drilling process to move from location to location, performing operations on large components.

The design of the GEN3SYS XT insert increases penetration rates, which can lower your production time and decrease operation costs. Available in multiple material-specific geometries, the GEN3SYS XT has a solution for most applications.

OUR SOLUTION

GEN3SYS® XT Vacuum Drill



- Spent coolant and chips are evacuated through an internal flute
- Guided body diameter to run through a drill bushing
- Replaceable tip for quick and easy insert change

YOUR ADVANTAGE

The sealed vacuum system lets you move your drilling operations outside the confines of a machine, allowing you to increase productivity on massive components.

✓ The same holder can be used for a range of diameters

✓ The same holder can be used for different material-specific inserts

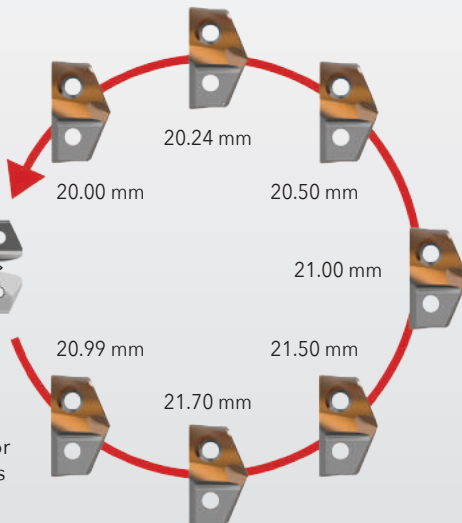

MATERIAL TIPS

Drilling in CFRP (Carbon Fiber Reinforced Polymer)

- These applications are run with the vacuum only (no coolant)
- Can be run with or without a micro peak cycle

Drilling in Metal

- These applications are run with the vacuum and coolant or mist
- Recommended to be run with a micro peak cycle

✓ Materials remain contained in a sealed vacuum system

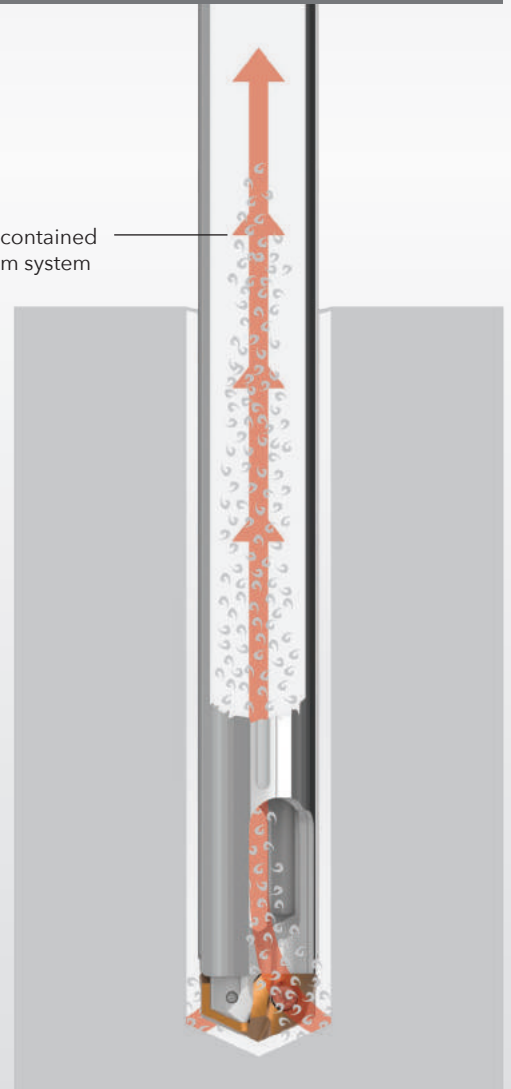

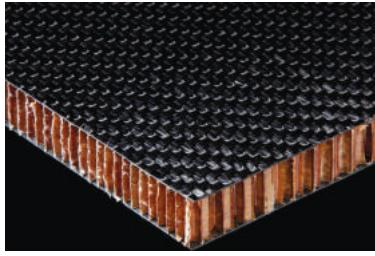

Carbon fiber material is ideal for industries that require components with high strength and rigidity without increasing weight. In other words, these products need to be really strong and sturdy but also really light. The aerospace industry revolves around aerodynamics, which is why carbon fiber is utilized to increase the quality of aerospace components without increasing the weight.

Many other metals are composed of uniform properties that are the same in every direction. Carbon fiber, on the other hand, is made of fabrics that are specifically positioned in different directions. This configuration increases the strength and rigidity of the material, but it also makes carbon fiber much more difficult to drill.

OUR **SOLUTION**

T-A[®] PCD Drill Insert

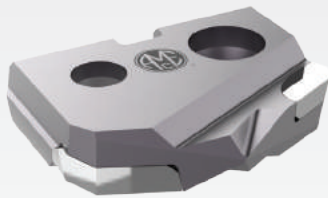

- C3 carbide substrate increases tool life
- PCD tip is specifically designed for carbon reinforced polymer (CFRP) material
- Notch Point[®] geometry, special corner clip, and drill point angle help minimize delamination upon exiting the hole

YOUR **ADVANTAGE**

Take control of carbon fiber reinforced polymer applications. The T-A PCD drill insert can provide the hole quality you need to produce successful quality parts and reduce scrap.

Polycrystalline Diamond Insert

What allows the polycrystalline diamond (PCD) insert to generate such high success in aerospace carbon fiber is the sharp cutting edge that provides clearance cutting and reduces delamination. The PCD wafers improve the wear resistance.

While other tools encounter massive tearing when exiting the hole in carbon fiber, the PCD insert geometry, along with precise OD corner prep and Notch Point[®] technology, encounters minimal delamination. This produces a near-perfect, tight tolerance and smooth hole (see the images below).

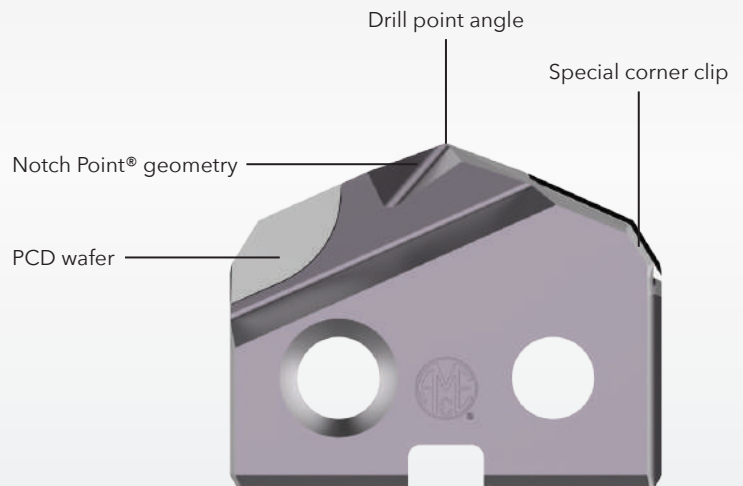

Results When Drilling Aerospace-Grade Carbon Fiber

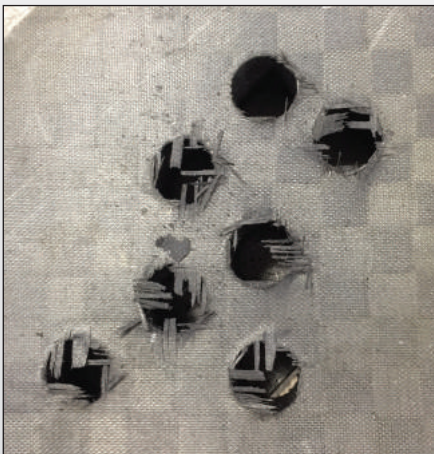

Holes drilled with CVD insert

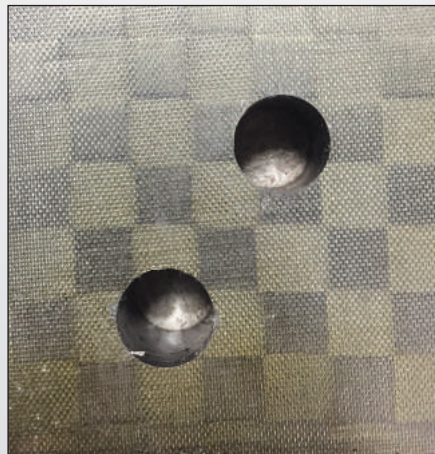

Holes drilled with Allied's T-A[®] PCD insert

Just Look at That!

These images tell the whole story. Check out the holes drilled by the T-A PCD insert versus the CVD insert. Notice the excessive delamination on the first group of holes. The PCD insert avoids most delamination, resulting in an excellent hole in the difficult-to-drill carbon fiber material.

Carbon fiber has high strength that causes:

- Wear on the cutting tool
- Splintering/fraying of the hole

As you can see, the first test experienced these problems. The T-A PCD insert, however, successfully drilled clean holes.



OUR SOLUTION

Special APX™ Modular Drill

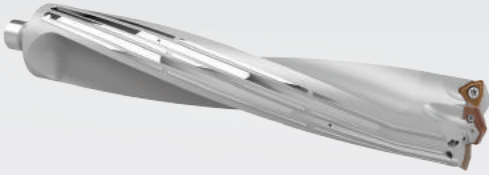

- Carbide clad bearing surface helps alignment and stability
- Coolant ports along the body keep the drill cool and lubricated
- Threaded shank allows for use with portable drill motors that use drill bushing guides

YOUR ADVANTAGE

Guided tooling with indexable inserts allows for a cost-effective, reliable drilling process even in difficult applications.

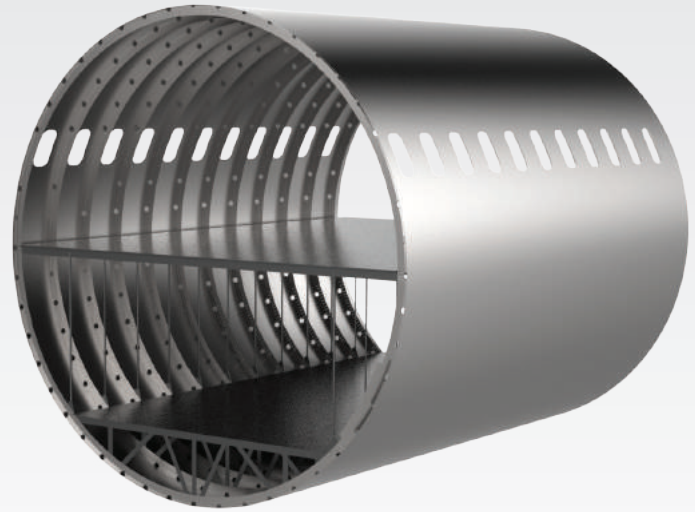

OUR SOLUTION

Special GEN3SYS® XT High Penetration Drill



- Double margin chromed bearing surface helps disperse heat
- Coolant through designed to aid in deep hole drilling and chip evacuation
- Threaded shank allows for use with portable drill motors that use drill bushing guides

YOUR ADVANTAGE

The increased stability, along with the ability to maintain penetration rates through interruptions and on breakout, provides increased production and greater profits.

OUR SOLUTION

Special GEN3SYS® XT High Penetration Drill

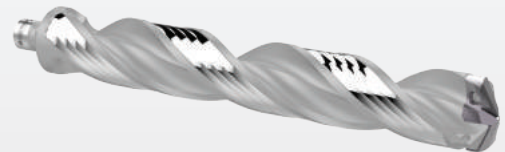

- Helical chromed bearing surface helps alignment and stability
- Coolant through designed to aid in deep hole drilling and chip evacuation
- Threaded shank allows for use with portable drill motors that use drill bushing guides

YOUR ADVANTAGE

The chrome bearing provides increased stability in highly demanding applications. You can increase your production rate by eliminating semi-finish passes and maintaining high penetration rates through interruptions.



OUR SOLUTION | Housing

T-A® Replaceable Insert Drill



- Large variety of geometries and coatings optimizes chip formation in various materials
- Replaceable insert increases productivity by reducing setups and downtimes
- Effectively disperses heat, which increases tool life and reduces overall costs

YOUR ADVANTAGE

The large assortment of geometries available with the T-A drilling system allows for a consistent drilling process you can rely on regardless of material.



OUR SOLUTION | Body

Revolution Drill® Indexable Insert Drill



- Drills from solid with no pilot hole required
- Replaceable cartridges allow the tool to be rebuilt and also make the diameter adjustable
- Robust geometry allows the tool to drill through uneven surfaces and interrupted cuts

YOUR ADVANTAGE

The Revolution Drill provides ideal performance on low horsepower machines while maintaining high penetration rates. These capabilities make the drill an excellent solution for large holes.

OUR SOLUTION

ThreadMills USA™ Solid Carbide Thread Mill



- The standard cutting lengths accommodate multiple applications without the need for a special
- One tool can run both right and left hand threads, reducing your inventory requirements
- Also available with coolant through capabilities

YOUR ADVANTAGE

Thread mills drastically reduce the occurrences of scrap when compared to taps, and this advantage makes them desirable when manufacturing large and/or costly components.



OUR SOLUTION | Cylinder

Wohlhaupter® VarioBore



- Provides precise hole sizes
- Simple diameter adjustment with the 3ETECH+ Digital Module
- Versatile setups for future jobs



3ETECH+

Digital Module

NOTE: Imperial display pictured

NOTE: Adjustment accuracy of 0.0001" or 0.001 mm on diameter

YOUR ADVANTAGE

A removable 3ETECH+ Digital Module turns many vernier VarioBore tools (equipped with 3ETECH docking port) into easy-to-read digital boring tools.



OUR SOLUTION | Clevis

GEN3SYS® XT High Penetration Drill



- Increases penetration rates and tool life
- Provides excellent chip control, improved durability, and added stability
- Available in different geometries based on the material you're drilling

YOUR ADVANTAGE

The replaceable insert and aggressive geometry options, including AS (Austenitic Stainless), allow you to match or outperform penetration rates of solid carbide tooling. The ability to replace the inserts on the spindle provides cost benefits by reducing machine downtime and setups.

OUR SOLUTION | Clevis

ALVAN® Replaceable Head Style Reamer

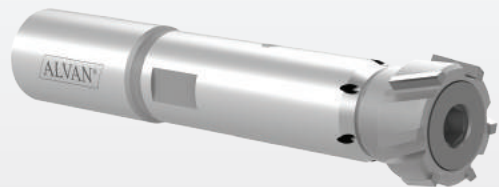

- Heads can be reconditioned
- Available in carbide, cermet, PCD, and CBN
- Provides tight tolerances (± 0.0002 ") and improves the surface finish of the hole
- Each arbor can be used with a range of head diameters, which reduces inventory costs

YOUR ADVANTAGE

The replaceable head functionality increases tool life and reduces set-up times which can increase your cost savings, while also providing superior hole quality.



OUR **SOLUTION** | Cylinder

APX™ Modular Drill

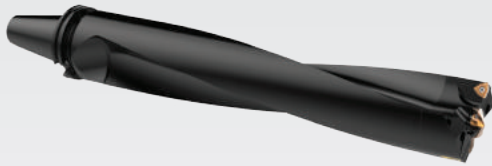

- Allows for higher spindle speeds and takes advantage of power curves on modern CNC machines
- Replaceable heads allow for size changes on the same holder body
- Ideal for large diameter and deep hole applications

► YOUR **ADVANTAGE**

The flexibility to use one body for multiple head sizes minimizes tooling investments while still providing optimal performance in many of your large diameter drilling operations.

OUR **SOLUTION** | Hydraulic Ports

AccuPort 432® Hydraulic Port Contour Cutter



- Drills and finishes port forms in one operation
- Replaces up to 5 tools: (1) end mill, (2) spot drill, (3) rough drill, (4) port tool, (5) reamer
- Specials include MS-33651 specification or special gauge lengths

► YOUR **ADVANTAGE**

The AccuPort 432 allows for increased performance and shorter cycle times by combining multiple operations into one tool. These tools are available in multiple standard port configurations.

OUR **SOLUTION**

Opening Drill® Indexable Insert Drill



- Opens an existing hole in a single operation
- Sliding cartridges create an adjustable diameter
- Eliminates multiple boring passes to improve cost-per-hole and decrease cycle time

► YOUR **ADVANTAGE**

The Opening Drill provides ideal performance on low horsepower machines while maintaining high penetration rates. These capabilities make the drill an excellent solution for large holes.

OUR **SOLUTION**

BT-A (STS) Replaceable Insert Drill



- Double effective cutting allows up to 2x the penetration rate over conventional BTA heads
- Uses standard BTA-STs tube connection
- Improves performance in cross holes

► YOUR **ADVANTAGE**

The versatility of available T-A geometries and substrates allows for increased penetration rates and excellent chip control in any application.



OUR SOLUTION

Special T-A® Stealth Drill



- Multiple coolant outlets along the holder body provide stability in deep holes and improves chip evacuation
- Adjustable screw pins allow for diameter adjustment to reduce TIR
- Guided wear pads improve hole straightness

YOUR ADVANTAGE

This specially designed guided T-A holder, paired with the versatility of the T-A insert, makes your difficult deep hole drilling applications worry-free even in applications with interruptions and angled breakouts.

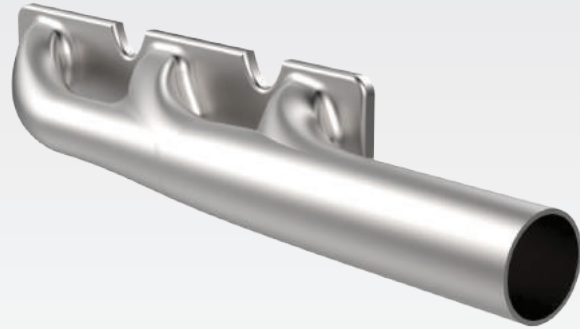

OUR SOLUTION

AccuPort 432® (Mil Spec) Port Contour Cutter



- Drills and finishes the port form with one tool
- Decreases cycle time, which improves your overall production
- Replaces up to 5 tools: (1) end mill, (2) spot drill, (3) rough drill, (4) port tool, (5) reamer

YOUR ADVANTAGE

The AccuPort 432 allows for increased performance and shorter cycle times by combining multiple operations into one tool. These tools are available in multiple standard port configurations.

OUR SOLUTION

AccuThread® 856 Replaceable Pin Style Thread Mill



- The holders are designed to dampen vibration, providing a smooth cut
- The replaceable inserts reduce inventory costs
- The pin style connection improves repeatability when changing inserts

YOUR ADVANTAGE

Thread mills drastically reduce the occurrences of scrap when compared to taps, and this advantage makes them desirable when manufacturing large and/or costly components.



OUR **SOLUTION** | Hydraulic Manifold

Special Guided T-A® Replaceable Insert Drill



- Bolt-in guide pads or brazed pads increase straightness and rigidity
- Special flat bottom inserts can be used with the same holder to create the form in the bottom of the hole
- Replaces 3 tools: (1) drill, (2) boring tool, and (3) end mill

▶ YOUR **ADVANTAGE**

This specially designed guided T-A holder, paired with the versatility of the T-A insert, makes your difficult deep hole drilling applications worry-free, even in applications with interruptions and angled breakouts.

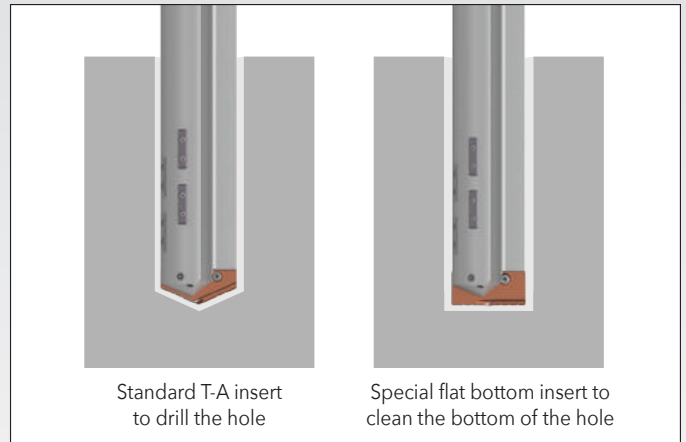

OUR **SOLUTION** | Hydraulic Manifold

ALVAN® Ring Style Modular Reamer



- Available in a variety of geometries for precision finishes
- Asymmetrical cutting edges provide excellent hole roundness
- Expandable up to 4% of nominal diameter to accommodate for wear

▶ YOUR **ADVANTAGE**

The cutting ring can be expanded to increase tool life. The ring can also be reconditioned, which makes it an excellent solution for reaming large diameters.

OUR **SOLUTION** | Hydraulic Manifold

Special T-A® Replaceable Insert Step/Port Drill



- The smaller diameter port tool is ideal for connecting cross holes
- Utilizes standard T-A and IC inserts
- Performs multiple steps in one process, eliminating the need for additional tooling and operations

▶ YOUR **ADVANTAGE**

Our special step port tooling not only saves on cycle time, but it also reduces programming time and opens up tool changer positions, allowing you to have more machine flexibility.



OUR SOLUTION

Special T-A® Stealth Drill

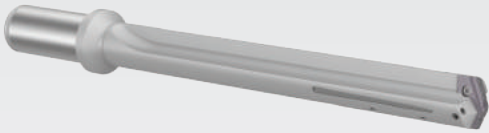

- Multiple coolant outlets along the holder body provides stability in deep holes and improves chip evacuation
- Adjustable pin allows for reduction in TIR to improve overall performance
- Guided wear pads improve hole straightness

YOUR ADVANTAGE

This specially designed guided T-A holder, paired with the versatility of the T-A insert, makes your difficult deep hole drilling applications worry-free, even in applications with interruptions and angled breakouts.



OUR SOLUTION

GEN3SYS® XT Pro High Penetration Drill



- Redesigned coolant configuration increases coolant flow to the cutting zone
- Wider flute design provides improved chip evacuation
- Different geometry/coating combinations designed for ISO-specific materials

YOUR ADVANTAGE

With increased coolant at the cutting zone, the XT Pro inserts stay cooler and experience longer tool life. The increased coolant exposure also allows the tool to achieve maximum penetration rates, which can help increase your throughput.

OUR SOLUTION

Superion® Solid Carbide Drill



- Multi-step tool available to reduce cycle times, tooling costs, and tool indexes
- Multiple coatings available to extend tool life and increase penetration rates in various materials
- PCD available to tackle high-volume CFRP and aluminum jobs

YOUR ADVANTAGE

Superion solid carbide solutions provide you with a quality tool in the time you need it, all at a cost that makes you effective. Solid carbide step tools drill a finished hole in tolerance while achieving long tool lives, making Superion an ideal solution for high production applications.



OUR SOLUTION

Special T-A® Step Drill



- Performs multiple steps in one process, eliminating the need for additional tooling and operations
- Improves chip formation
- Utilizes standard T-A and IC inserts

YOUR ADVANTAGE

The special T-A step drill not only reduces the number of machining operations required, but it also reduces programming time and opens up tool changer positions, allowing you to have more machine flexibility.



OUR SOLUTION

Superion® Helical Step Drill

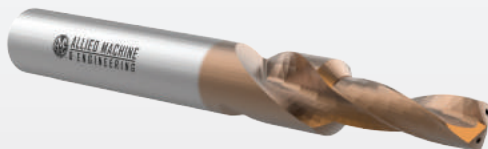

- Coolant through solid carbide tooling drives high penetration rates and long tool life
- Multiple coatings available to extend tool life and increase penetration rates in various materials
- PCD available to tackle high-volume CFRP and aluminum jobs

YOUR ADVANTAGE

Coolant through capabilities, along with specific coatings, provide extended tool life and increased penetration rates. These benefits can decrease your tooling costs and even reduce your overall operation costs.

OUR SOLUTION | Hydraulic Manifold

AccuThread® 856 Solid Carbide Thread Mill



- Standard cutting lengths accommodate multiple applications without the need for a special
- Provides increased strength and rigidity when cutting forces are applied
- Allied's AM210® coating provides 25-50% in tool life over competitive products

YOUR ADVANTAGE

With Allied's online programming tool, Insta-Code®, you can select a thread mill and easily create the program code for your machine. With both an online version and desktop download version, you can create programs anytime, anywhere.



OUR SOLUTION | Rod Ends

Wohlhaupter® VarioBore



- Provides precise hole sizes
- Simple diameter adjustment with the 3ETECH+ Digital Module
- One head can bore multiple holes ranging from 0.016" - 5.984" (0.4 mm - 152 mm)



3ETECH+

Digital Module

NOTE: Imperial display pictured

NOTE: Adjustment accuracy of 0.0001" or 0.001 mm on diameter



YOUR ADVANTAGE

Keeping different tools stocked for various applications can be costly. The VarioBore provides versatility that minimizes your tooling costs and keeps you prepared for the work tomorrow will bring.

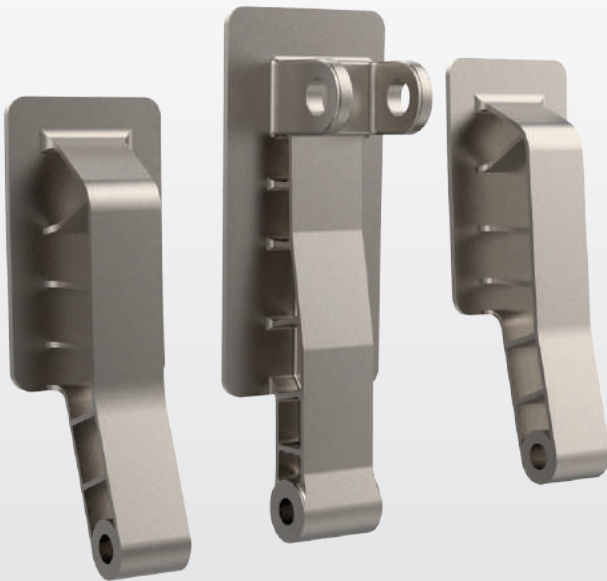

OUR SOLUTION | Wing Hinges

Wohlhaupter® 365 Boring Head



- Internal automatic balancing provides consistent hole size and superior surface finish
- Carbide shank allows for deeper length-to-diameter ratios
- Vernier scale for 0.0001" (0.002 mm) accurate adjustments

YOUR ADVANTAGE

The 365 Boring Head with carbide shank provides boring solutions for bores that were previously too deep to achieve.

OUR **SOLUTION** | Fasteners

Wohlhaupter® 249 Boring Head



- Small head diameter allows for high spindle speeds
- Utilized to achieve long reach
- Can be used with carbide shanks or tool steel

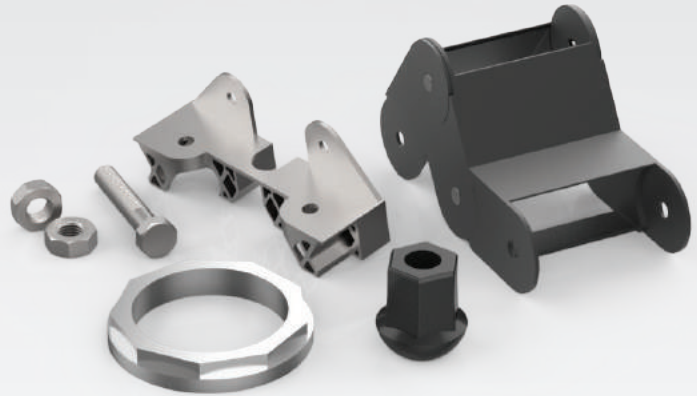

YOUR **ADVANTAGE**

The 249 Boring Head's cylindrical shank allows for infinite variable length adjustment up to 9:1 length-to-diameter ratio.



OUR **SOLUTION** | Components

Wohlhaupter® DigiBore



- Versatile set-ups for future jobs ranging from 0.118" - 8.189" (3 mm - 208 mm)
- Internal auto balancing provides consistent hole size and surface finish
- Digital readout for simple 0.0001" (0.002 mm) diameter adjustments

YOUR **ADVANTAGE**

DigiBore provides internal balancing, which makes this tool the stress-free choice when creating your required surface finish.



We Have the Answers



Whatever type of holmaking you do, Allied is here to help.

Whether you're a production facility producing thousands of parts for one customer, or a job shop making a handful of parts for hundreds of customers, we're here to make sure the job gets done. Our precision holmaking and finishing solutions are backed by our dedicated staff of knowledgeable engineers who are standing by, ready to help.

Don't hesitate to call us. Let us know what problems you're having and give us a chance to find the solution. Holmaking is what we do, so you can feel confident when seeking our advice to solve your application challenges.

All you have to do is ask.

For complete aerospace industry case studies, visit
www.alliedmachine.com/aerospace

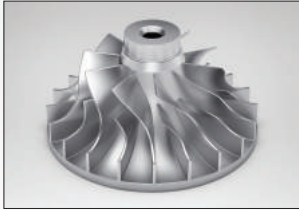

Notes

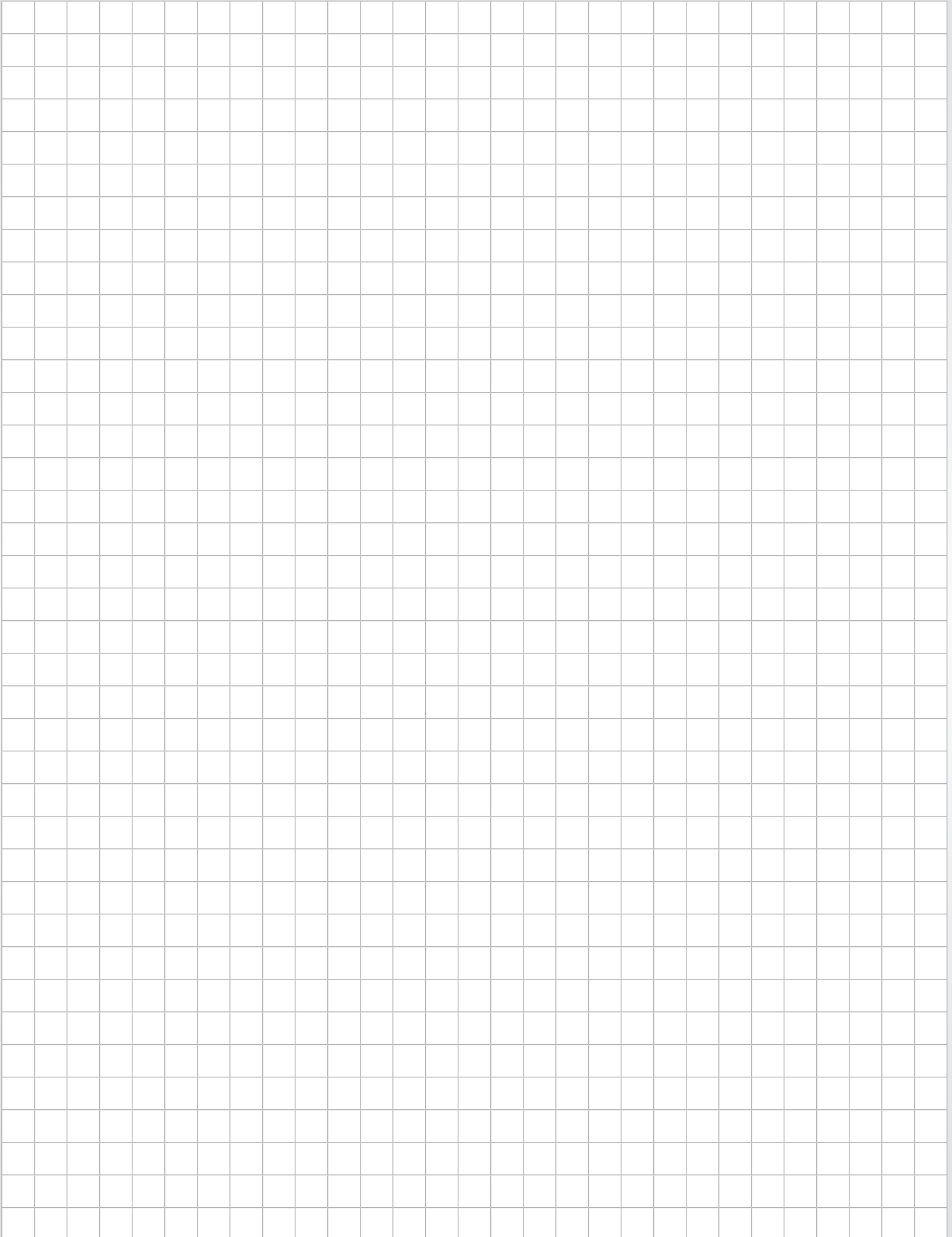

Warranty Information



Allied Machine & Engineering ("Allied Machine") warrants to original equipment manufacturers, distributors, industrial and commercial users of its products for one year from the original date of sale that each new product manufactured or supplied by Allied Machine shall be free from defects in material and workmanship.

Allied Machine's sole and exclusive obligation under this warranty is limited to, at its option, without additional charge, replacing or repairing this product or issuing a credit. For this warranty to be applied, the product must be returned freight prepaid to the plant designated by an Allied Machine representative and which, upon inspection, is determined by Allied Machine to be defective in material and workmanship.

Complete information as to operating conditions, machine, setup, and the application of cutting fluid should accompany any product returned for inspection. This warranty shall not apply to any Allied Machine products which have been subjected to misuse, abuse, improper operating conditions, improper machine setup or improper application of cutting fluid or which have been repaired or altered if such repair or alteration, in the judgement of Allied Machine, would adversely affect the performance of the product.

THIS WARRANTY IS IN LIEU OF ALL OTHER WARRANTIES, EXPRESS OR IMPLIED, INCLUDING ANY IMPLIED WARRANTY OF MERCHANTABILITY OR FITNESS FOR A PARTICULAR PURPOSE. Allied Machine shall have no liability or responsibility for any claim, whether in contract, tort or otherwise, for any loss or damage arising out of, connected with, or resulting from the manufacture, sale, delivery or use of any product sold hereunder, in excess of the cost of replacement or repair as provided herein.

Allied Machine shall not be liable in contract or in tort (including, without limitation, negligence, strict liability or otherwise) for economic losses of any kind or for any special, incidental, indirect, consequential, punitive or exemplary damages arising in any way out of the performance of, or failure to perform this agreement.

ALL PRICES, DELIVERIES, DESIGNS, AND MATERIALS ARE SUBJECT TO CHANGE WITHOUT NOTICE.



Allied Machine & Engineering
is registered to
ISO 9001:2015 by DQS



Wohlhaupter GmbH
is registered to
ISO 9001:2015 by QA TECHNICH

United States

Allied Machine & Engineering
120 Deeds Drive
Dover OH 44622
United States

Phone:
+1.330.343.4283

Fax:
+1.330.602.3400

Toll Free USA and Canada:
800.321.5537

Toll Free USA and Canada:
800.223.5140

Allied Machine & Engineering
485 W Third Street
Dover OH 44622
United States

Phone:
+1.330.343.4283

Fax:
+1.330.364.7666
(Engineering Dept.)

Toll Free USA and Canada:
800.321.5537

Europe

Allied Machine & Engineering Co. (Europe) Ltd.
93 Vantage Point
Pensnett Estate
Kingswinford
West Midlands
DY6 7FR England

Phone:
+44 (0) 1384.400900

Wohlhaupter GmbH
Maybachstrasse 4
Postfach 1264
72636 Frickenhausen
Germany

Phone:
+49 (0) 7022.408.0

Fax:
+49 (0) 7022.408.212

Asia

Wohlhaupter India Pvt. Ltd.
B-23, 3rd Floor
B Block Community Centre
Janakpuri, New Delhi - 110058
India

Phone:
+91 (0) 11.41827044

Your local Allied Machine representative:

www.alliedmachine.com

Allied Machine & Engineering is registered to **ISO 9001:2015** by DQS
Wohlhaupter GmbH is registered to **ISO 9001:2015** by QTA TECHNIC



Copyright © 2023 Allied Machine & Engineering Corp. All rights reserved.
All trademarks designated with the ® symbol are registered in the United States and other countries.

Publish Date: August 2023