



**ALLIED MACHINE
& ENGINEERING**

WOHLHAUPTER®

Holemaking Solutions for Today's Manufacturing



Drilling



Reaming



Burnishing



Threading



Specials



Wohlhaupter®

► **BORING**

Master Shanks with MVS Connection

WOHLHAUPTER®



SECTION

B10-F

Master Shanks with MVS Connection

Wohlhaupter® Master Shanks with MVS Connection



The MVS Connection

Wohlhaupter MVS connection shanks provide a high level of accuracy when building or replacing components. Our master shanks adapt to any machine tool spindle, making it easy to find the shank you need.

Your safety and the safety of others is very important. This catalogue contains important safety messages. Always read and follow all safety precautions.



This triangle is a safety hazard symbol. It alerts you to potential safety hazards that can cause tool failure and serious injury.

When you see this symbol in the catalogue, look for a related safety message that may be near this triangle or referred to in the nearby text.

There are safety signal words also used in the catalogue. Safety messages follow these words.

WARNING

WARNING (shown above) means that failure to follow the precautions in this message could result in tool failure and serious injury.

NOTICE means that failure to follow the precautions in this message could result in damage to the tool or machine but not result in personal injury.

NOTE and **IMPORTANT** are also used. These are important that you read and follow but are not safety-related.

Visit www.alliedmachine.com for the most up-to-date information and procedures.

Applicable Industries



Aerospace



Agriculture



Automotive



Firearms



General
Machining



Oil & Gas



Renewable
Energy

Reference Icons

The following icons will appear throughout the catalogue to help you navigate between products.

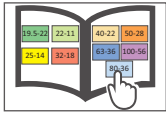

MVS Connection Colour Guide
Detailed instructions and information regarding the MVS connection(s)

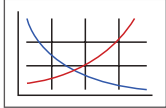

Recommended Cutting Data
Speed and feed recommendations for optimum and safe boring

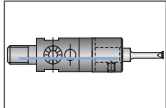

248 Boring Head
248 boring head that connects into the adapter shanks

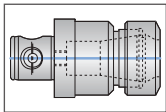

Clamping Elements
Collet chucks for carbide shanks



Through Coolant Option
Indicates that the product is through coolant

Master Shanks with MVS Connection Table of Contents

248 Shanks	2
Carbide Shanks	3
HSK Shanks (DIN 69893)	4
Polygon Shaft Shanks (PSC) (ISO26623-1)	5
CAT Shanks with Metric Threads	6
Dual Contact SK Shanks (DIN 69871-AD / B -D)	7
SK Shanks (DIN 69871-AD / B -D)	8
Dual Contact BT Shanks (JIS B 6339)	9
BT Shanks (JIS B 6339)	10
NMTB Shanks	11
DIN 2080 Shanks	12
Morse Taper Shanks (DIN 1806) & R8 Shanks	13
Accessories	14 - 15
Mounting Fixtures	16

248 Shanks

Steel | Carbide

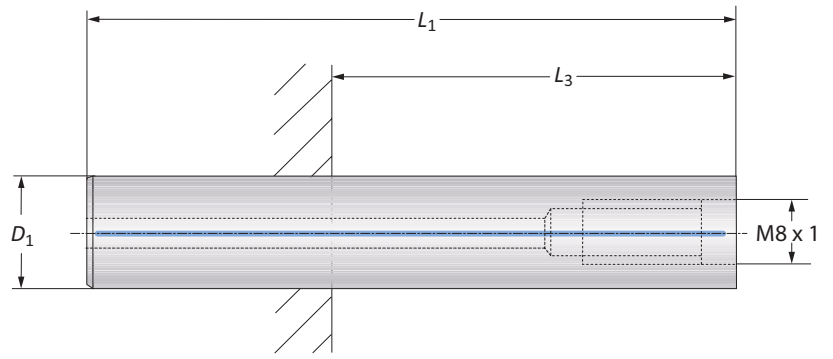

Steel Shanks

Connection	Shank			L_3 min*				Weight	Part No.
	D_1	L_1	L_3 max*	SK 40+50	HSK-A 63	HSK-A 100			
M8 x 1	15.00	85.00	37.00	-	-	-	0.10 (kg)	248136	
M8 x 1	18.00	100.00	52.00	-	5.00	12.00	0.20 (kg)	248137	
M8 x 1	23.00	117.00	69.00	-	22.00	29.00	0.40 (kg)	248138	

* L_3 dimensions apply to collet chucks.

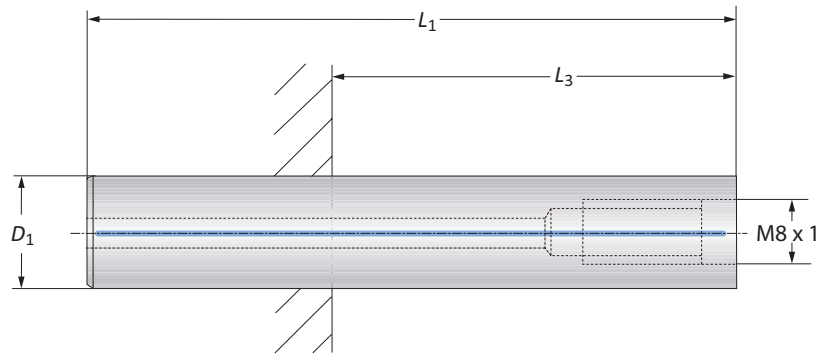

Carbide Shanks

Connection	Shank			L_3 min*				Weight	Part No.
	D_1	L_1	L_3 max*	SK 40	SK 50	HSK-A 63	HSK-A 100		
M8 x 1	15.00	130.00	82.00	20.00	20.00	35.00	42.00	0.30 (kg)	248142
M8 x 1	18.00	155.00	107.00	39.00	21.00	60.00	67.00	0.60 (kg)	248143
M8 x 1	23.00	180.00	132.00	64.00	46.00	85.00	92.00	1.10 (kg)	248144
M8 x 1	23.00	242.00	194.00	126.00	108.00	147.00	154.00	1.40 (kg)	248145

* L_3 dimensions apply to collet chucks.

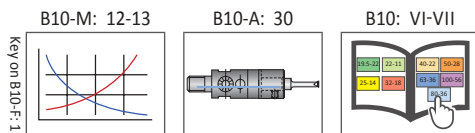

Ⓜ = Metric (mm)

⚠ WARNING Exceeding weight capacity for machine tool spindle and tool changer can cause machine damage and/or serious injury. To prevent:
 -Consult machine tool builder for machine's weight limitations.
 -Refer to example on page B10-M: 11 for calculating tool assembly weight.
 Factory technical assistance is also available for specific applications through our Application Engineering department. *email: engineering.eu@alliedmachine.com*

⚠ WARNING Tool failure can cause serious injury. To prevent:
 -Do not exceed recommended 10xD length-to-diameter ratio or exceed 4 total components (including shank).
 -When using Alu-Line® components, do not exceed recommended 5xD length-to-diameter ratio.
 -When using tool steel components, do not exceed recommended 6xD length-to-diameter ratio.
 -When using heavy metal components, do not exceed recommended 8xD length-to-diameter ratio.
 -When using a carbide shank, do not exceed recommended 9xD length-to-diameter ratio.
 -When using a NOVITECH® module, do not exceed recommended 10xD length-to-diameter ratio.
 -Refer to examples on pages B10-M: 8-10 for calculating length-to-diameter ratio.
 Factory technical assistance is available for your specific applications through our Application Engineering department. *email: engineering.eu@alliedmachine.com*

A
B
C
D
E
F
G
H
I
J
K
L
M
INDEX

Carbide Master Shanks

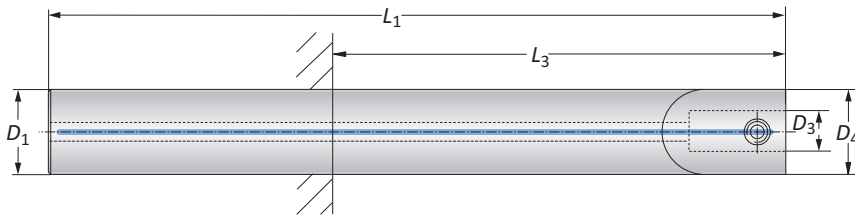

Connection	Shank			L_3 min				Weight	Part No.	
	D_4 D_3	L_1	D_1	L_3 max	SK 40	SK 50	HSK-A 63			HSK-A 100
M	18 - 11	155.00	18.00	107.00	39.00	26.00	60.00	67.00	0.50 (kg)	299009*
	22 - 11	140.00	22.00	92.00	28.00	28.00	45.00	52.00	0.70 (kg)	299001*
	22 - 11	190.00	22.00	142.00	74.00	56.00	95.00	102.00	0.90 (kg)	299002*
	22 - 11	231.00	22.00	183.00	115.00	97.00	136.00	143.00	1.10 (kg)	299003*
	25 - 14	165.00	25.00	117.00	49.00	36.00	70.00	77.00	1.00 (kg)	299004*
	25 - 14	215.00	25.00	167.00	99.00	81.00	120.00	127.00	1.30 (kg)	299005*
	32 - 18	210.00	32.00	-	136.00	136.00	139.00	137.00	2.10 (kg)	299006**
	32 - 18	260.00	32.00	-	186.00	186.00	189.00	187.00	2.60 (kg)	299007**
40 - 22	415.00	40.00	-	-	333.00	-	333.00	5.20 (kg)	299008**	

NOTE: Adapter shanks are used for extensions up to 10xD.

*Recommended clamping element: collet chuck ISO 15488 (DIN 6499-B) (pg. B10-I: 4).

**Recommended clamping element: collet chuck ISO 10897 (DIN 6388) (pg. B10-I: 4).

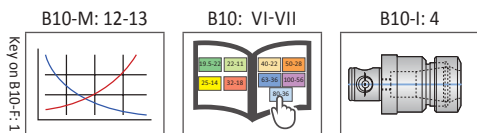

M = Metric (mm)

⚠ WARNING Exceeding weight capacity for machine tool spindle and tool changer can cause machine damage and/or serious injury. To prevent:
 -Consult machine tool builder for machine's weight limitations.
 -Refer to example on page B10-M: 11 for calculating tool assembly weight.
 Factory technical assistance is also available for specific applications through our Application Engineering department. *email: engineering.eu@alliedmachine.com*

⚠ WARNING Tool failure can cause serious injury. To prevent:
 -Do not exceed recommended 10xD length-to-diameter ratio or exceed 4 total components (including shank).
 -When using Alu-Line® components, do not exceed recommended 5xD length-to-diameter ratio.
 -When using tool steel components, do not exceed recommended 6xD length-to-diameter ratio.
 -When using heavy metal components, do not exceed recommended 8xD length-to-diameter ratio.
 -When using a carbide shank, do not exceed recommended 9xD length-to-diameter ratio.
 -When using a NOVITECH® module, do not exceed recommended 10xD length-to-diameter ratio.
 -Refer to examples on pages B10-M: 8-10 for calculating length-to-diameter ratio.
 Factory technical assistance is available for your specific applications through our Application Engineering department. *email: engineering.eu@alliedmachine.com*

HSK Master Shanks (DIN 69893)

Balanced

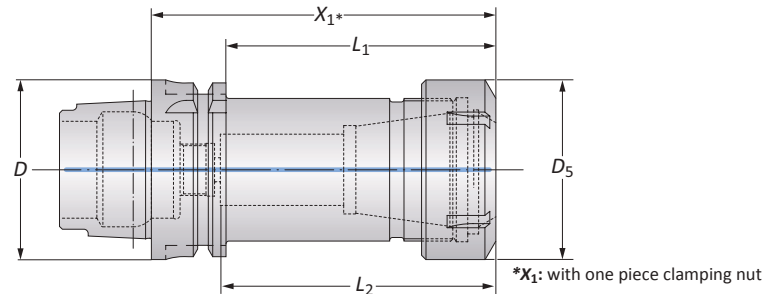
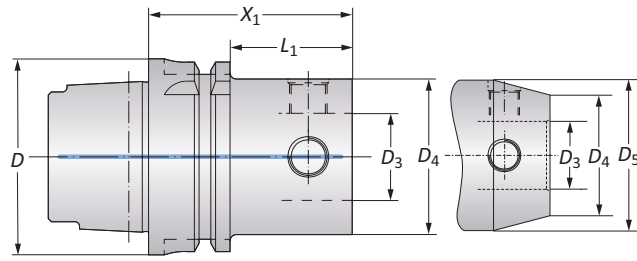

Taper Size	Connection	Shank				Weight	Part No.
		D	D ₄ D ₃	X ₁	L ₁		
40	40 - 22	56.00	-	-	-	0.40 (kg)	246016
40	50 - 28	70.00	-	-	-	0.70 (kg)	246004
50	40 - 22	56.00	30.00	-	-	0.60 (kg)	246015
50	50 - 28	65.00	-	-	-	0.80 (kg)	245011
63	25 - 14	46.00	20.00	-	-	0.70 (kg)	246012
63	32 - 18	56.00	30.00	-	-	0.80 (kg)	246013
63	40 - 22	56.00	30.00	-	-	0.80 (kg)	246014
63	50 - 28	65.00	39.00	-	-	1.10 (kg)	245012
63	63 - 36	80.00	-	-	-	1.50 (kg)	245013
63	80 - 36	80.00	-	-	-	2.10 (kg)	246009
63	ER 40	120.00	94.00	95.00	63.00	1.70 (kg)	252090**
100	50 - 28	65.00	36.00	-	-	2.40 (kg)	245014
100	50 - 28	180.00	151.00	-	60.00	5.00 (kg)	246020
100	50 - 28*	180.00	151.00	-	-	4.00 (kg)	246021
100	63 - 36	80.00	51.00	-	-	2.90 (kg)	245015
100	63 - 36	205.00	176.00	-	78.00	7.80 (kg)	246019
100	63 - 36	205.00	176.00	-	-	7.80 (kg)	246022
100	80 - 36	80.00	51.00	-	-	3.70 (kg)	245016
100	80 - 36	255.00	226.00	-	90.00	12.60 (kg)	246018
100	80 - 36	255.00	226.00	-	-	10.40 (kg)	246023
100	100 - 56	100.00	-	-	-	5.00 (kg)	246010
100	100 - 56	300.00	221.00	-	-	17.50 (kg)	246017
100	ER 40	120.00	91.00	88.00	63.00	3.50 (kg)	252091**

NOTE: Balanced refers to a specific residual imbalance of ≤4.00 gmm/kg.

*D₄ = 49.50 mm

**Balanced without clamping nut.

B10-M: 12-13

B10: VI-VII

Key on B10-F: 1

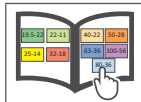
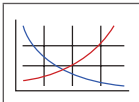

Ⓜ = Metric (mm)

⚠ WARNING Exceeding weight capacity for machine tool spindle and tool changer can cause machine damage and/or serious injury. To prevent:

-Consult machine tool builder for machine's weight limitations.

-Refer to example on page B10-M: 11 for calculating tool assembly weight.

Factory technical assistance is also available for specific applications through our Application Engineering department. *email: engineering.eu@alliedmachine.com*

⚠ WARNING Tool failure can cause serious injury. To prevent:

-Do not exceed recommended 10xD length-to-diameter ratio or exceed 4 total components (including shank).

-When using Alu-Line® components, do not exceed recommended 5xD length-to-diameter ratio.

-When using tool steel components, do not exceed recommended 6xD length-to-diameter ratio.

-When using heavy metal components, do not exceed recommended 8xD length-to-diameter ratio.

-When using a carbide shank, do not exceed recommended 9xD length-to-diameter ratio.

-When using a NOVI^{TECH} module, do not exceed recommended 10xD length-to-diameter ratio.

-Refer to examples on pages B10-M: 8-10 for calculating length-to-diameter ratio.

Factory technical assistance is available for your specific applications through our Application Engineering department. *email: engineering.eu@alliedmachine.com*

Polygon Shaft Master Shanks (PSC) (ISO 26623-1)

Balanced

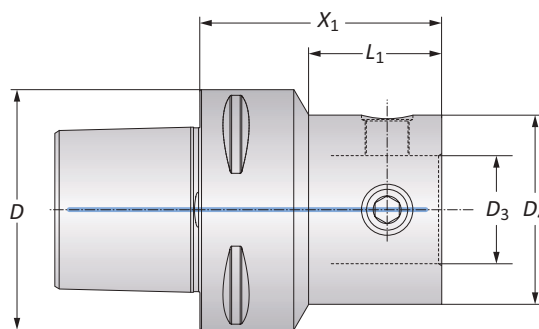
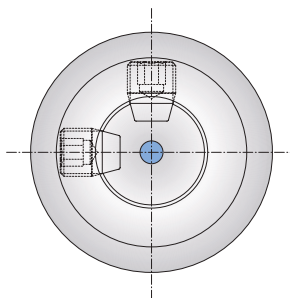

PSC	Connection	Shank		Weight	Part No.	
		D_4 D_3	X_1			L_1
m	50	40 - 22	54.00	31.10	0.70 (kg)	227014
	50	50 - 28	65.00	-	1.00 (kg)	227001
	50	63 - 36	80.00	-	1.50 (kg)	227002
	50	80 - 36	80.00	-	2.50 (kg)	227012
	63	25 - 14	54.00	21.10	0.90 (kg)	227010
	63	32 - 18	54.00	23.00	1.00 (kg)	227009
	63	40 - 22	65.00	36.40	1.10 (kg)	227008
	63	50 - 28	65.00	39.00	1.30 (kg)	227003
	63	63 - 36	80.00	-	1.80 (kg)	227004
	63	80 - 36	80.00	-	2.60 (kg)	227005
	80	50 - 28	65.00	25.00	2.20 (kg)	227011
	80	63 - 36	80.00	45.10	2.60 (kg)	227006
	80	80 - 36	80.00	-	3.30 (kg)	227007
	80	100 - 56	80.00	-	4.88 (kg)	227013

NOTE: Balanced refers to a specific residual imbalance of ≤ 4.00 gmm/kg.

B10-M: 12-13

B10: VI-VII

Key on B10-F: 1

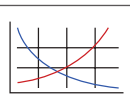

m = Metric (mm)

WARNING Exceeding weight capacity for machine tool spindle and tool changer can cause machine damage and/or serious injury. To prevent:

- Consult machine tool builder for machine's weight limitations.
- Refer to example on page B10-M: 11 for calculating tool assembly weight.
- Factory technical assistance is also available for specific applications through our Application Engineering department. *email: engineering.eu@alliedmachine.com*

WARNING Tool failure can cause serious injury. To prevent:

- Do not exceed recommended 10xD length-to-diameter ratio or exceed 4 total components (including shank).
- When using Alu-Line® components, do not exceed recommended 5xD length-to-diameter ratio.
- When using tool steel components, do not exceed recommended 6xD length-to-diameter ratio.
- When using heavy metal components, do not exceed recommended 8xD length-to-diameter ratio.
- When using a carbide shank, do not exceed recommended 9xD length-to-diameter ratio.
- When using a NOVITECH® module, do not exceed recommended 10xD length-to-diameter ratio.
- Refer to examples on pages B10-M: 8-10 for calculating length-to-diameter ratio.
- Factory technical assistance is available for your specific applications through our Application Engineering department. *email: engineering.eu@alliedmachine.com*

CAT Master Shanks with Metric Threads

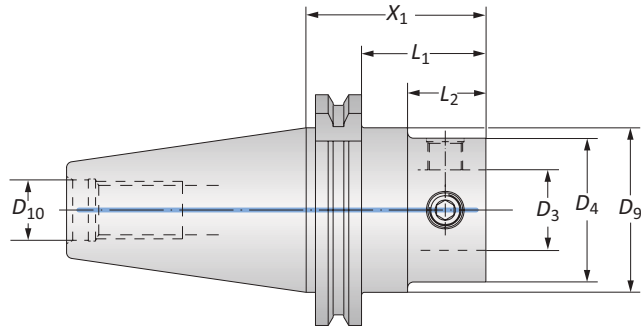

Taper Size	Connection		Shank				Weight	Part No.	
	D_4 D_3	X_1	L_1	L_2	D_9	D_{10}			
M	40	50 - 28	62.00	42.90	-	44.45	M16 x 2	1.30 (kg)	132022T016960
	40	63 - 36	82.00	62.90	-	44.45	M16 x 2	1.80 (kg)	132066T016960
	50	50 - 28	62.00	42.90	27.00	69.85	M24 x 3	3.40 (kg)	132022T016962
	50	63 - 36	72.00	52.90	37.00	69.85	M24 x 3	3.70 (kg)	132066T016962
	50	80 - 36	72.00	52.90	-	69.85	M24 x 3	4.20 (kg)	132088T016962
	50	100 - 56	105.00	85.90	-	69.85	M24 x 3	5.20 (kg)	132076T016962

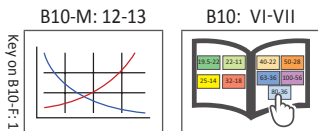

M = Metric (mm)

WARNING Exceeding weight capacity for machine tool spindle and tool changer can cause machine damage and/or serious injury. To prevent:
 -Consult machine tool builder for machine's weight limitations.
 -Refer to example on page B10-M: 11 for calculating tool assembly weight.
 Factory technical assistance is also available for specific applications through our Application Engineering department. *email: engineering.eu@alliedmachine.com*

WARNING Tool failure can cause serious injury. To prevent:
 -Do not exceed recommended 10xD length-to-diameter ratio or exceed 4 total components (including shank).
 -When using Alu-Line® components, do not exceed recommended 5xD length-to-diameter ratio.
 -When using tool steel components, do not exceed recommended 6xD length-to-diameter ratio.
 -When using heavy metal components, do not exceed recommended 8xD length-to-diameter ratio.
 -When using a carbide shank, do not exceed recommended 9xD length-to-diameter ratio.
 -When using a NOVITECH® module, do not exceed recommended 10xD length-to-diameter ratio.
 -Refer to examples on pages B10-M: 8-10 for calculating length-to-diameter ratio.
 Factory technical assistance is available for your specific applications through our Application Engineering department. *email: engineering.eu@alliedmachine.com*

A
B
C
D
E
F
G
H
I
J
K
L
M
INDEX

Dual Contact SK Master Shanks (DIN 69871-AD / B -D)

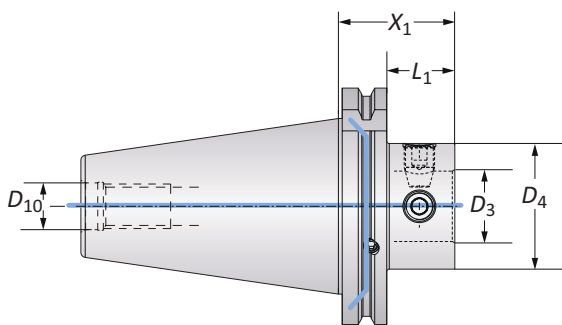

Taper Size	Connection	Shank			Weight	Part No.	
	$D_4 D_3$	X_1	L_1	D_{10}			
m	40	50 - 28	46.00	26.90	M16 x 2	1.10 (kg)	353064
	40	63 - 36	66.00	46.90	M16 x 2	1.50 (kg)	353065
	50	50 - 28	46.00	26.90	M24 x 3	2.90 (kg)	353066
	50	63 - 36	56.00	36.90	M24 x 3	3.20 (kg)	353067
	50	80 - 36	56.00	36.90	M24 x 3	3.70 (kg)	353068
	50	100 - 56	90.00	70.90	M24 x 3	5.30 (kg)	353069

B10-M: 12-13

B10: VI-VII

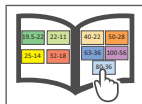
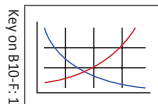

m = Metric (mm)

WARNING Exceeding weight capacity for machine tool spindle and tool changer can cause machine damage and/or serious injury. To prevent:

- Consult machine tool builder for machine's weight limitations.
- Refer to example on page B10-M: 11 for calculating tool assembly weight.
- Factory technical assistance is also available for specific applications through our Application Engineering department. *email: engineering.eu@alliedmachine.com*

WARNING Tool failure can cause serious injury. To prevent:

- Do not exceed recommended 10xD length-to-diameter ratio or exceed 4 total components (including shank).
- When using Alu-Line® components, do not exceed recommended 5xD length-to-diameter ratio.
- When using tool steel components, do not exceed recommended 6xD length-to-diameter ratio.
- When using heavy metal components, do not exceed recommended 8xD length-to-diameter ratio.
- When using a carbide shank, do not exceed recommended 9xD length-to-diameter ratio.
- When using a NOVITECH® module, do not exceed recommended 10xD length-to-diameter ratio.
- Refer to examples on pages B10-M: 8-10 for calculating length-to-diameter ratio.
- Factory technical assistance is available for your specific applications through our Application Engineering department. *email: engineering.eu@alliedmachine.com*

SK Master Shanks (DIN 69871-AD / B -D)

Balanced

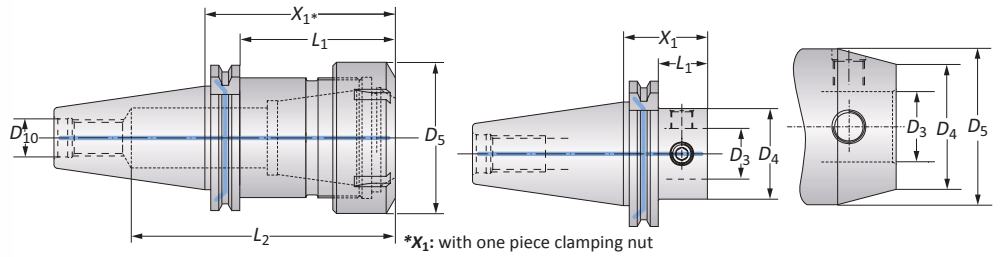

Taper Size	Connection D ₄ D ₃	Shank					Weight	Part No.
		X ₁	L ₁	L ₂	D ₅	D ₁₀		
30	40 - 22	46.00	26.90	-	-	M12 x 1.75	0.50 (kg)	327001
30	50 - 28	58.00	-	-	-	M12 x 1.75	0.80 (kg)	327002
40	32 - 18	55.00	35.90	-	40.00	M16 x 2	1.10 (kg)	327003
40	40 - 22	46.00	26.90	-	-	M16 x 2	1.00 (kg)	327004
40	50 - 28	46.00	26.90	-	-	M16 x 2	1.10 (kg)	327005
40	63 - 36	66.00	46.90	-	-	M16 x 2	1.40 (kg)	327006
40	80 - 36	66.00	-	-	-	M16 x 2	1.90 (kg)	327007
40	ER 40	80.00	60.90	116.00	63.00	M16 x 2	1.30 (kg)	259079**
50	50 - 28	46.00	26.90	-	-	M24 x 3	2.90 (kg)	327017
m 50	50 - 28	186.00	166.90	-	60.00	M24 x 3	6.00 (kg)	327025
50	50 - 28*	186.00	166.90	-	-	M24 x 3	4.90 (kg)	327033
50	63 - 36	56.00	36.90	-	-	M24 x 3	3.20 (kg)	327018
50	63 - 36	206.00	186.90	-	78.00	M24 x 3	8.90 (kg)	327026
50	63 - 36	206.00	186.90	-	-	M24 x 3	6.90 (kg)	327034
50	80 - 36	56.00	36.90	-	-	M24 x 3	3.70 (kg)	327010
50	80 - 36	256.00	236.90	-	90.00	M24 x 3	13.60 (kg)	327027
50	80 - 36	256.00	236.90	-	-	M24 x 3	11.50 (kg)	327035
50	100 - 56	90.00	-	-	-	M24 x 3	5.30 (kg)	327011
50	100 - 56	290.00	270.90	-	-	M24 x 3	17.10 (kg)	327028
50	ER 40	80.00	55.20	134.00	63.00	M24 x 3	3.10 (kg)	259080**

NOTE: Balanced refers to a specific residual imbalance of ≤4.00 gmm/kg.

* D₄ = (49.50 mm)

**Balanced without clamping nut.

B10-M: 12-13

B10: VI-VII

Key on B10-F: 1

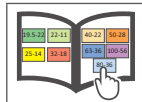
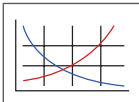

m = Metric (mm)

WARNING Exceeding weight capacity for machine tool spindle and tool changer can cause machine damage and/or serious injury. To prevent:
 -Consult machine tool builder for machine's weight limitations.
 -Refer to example on page B10-M: 11 for calculating tool assembly weight.
 Factory technical assistance is also available for specific applications through our Application Engineering department. *email: engineering.eu@alliedmachine.com*

WARNING Tool failure can cause serious injury. To prevent:
 -Do not exceed recommended 10xD length-to-diameter ratio or exceed 4 total components (including shank).
 -When using Alu-Line® components, do not exceed recommended 5xD length-to-diameter ratio.
 -When using tool steel components, do not exceed recommended 6xD length-to-diameter ratio.
 -When using heavy metal components, do not exceed recommended 8xD length-to-diameter ratio.
 -When using a carbide shank, do not exceed recommended 9xD length-to-diameter ratio.
 -When using a NOVITECH® module, do not exceed recommended 10xD length-to-diameter ratio.
 -Refer to examples on pages B10-M: 8-10 for calculating length-to-diameter ratio.
 Factory technical assistance is available for your specific applications through our Application Engineering department. *email: engineering.eu@alliedmachine.com*

Dual Contact BT Master Shanks (JIS B 6339)

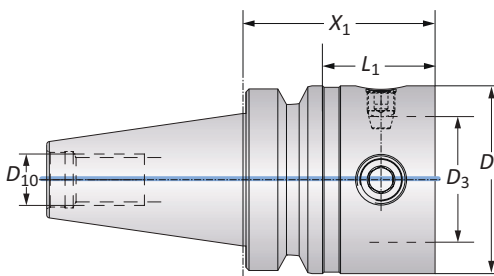

Taper Size	Connection		Shank			Weight	Part No.
	D_4 D_3	X_1	L_1	D_{10}			
M	40	50 - 28	54.00	27.00	M16 x 2	1.20 (kg)	353070
	40	63 - 36	64.00	37.00	M16 x 2	1.50 (kg)	353071
	50	50 - 28	65.00	26.80	M24 x 3	4.00 (kg)	353072
	50	63 - 36	75.00	36.80	M24 x 3	4.20 (kg)	353073
	50	80 - 36	75.00	36.80	M24 x 3	4.80 (kg)	353074
	50	100 - 56	90.00	51.80	M24 x 3	5.50 (kg)	353075

B10-M: 12-13

B10: VI-VII

Key on B10-F: 1

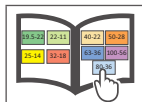
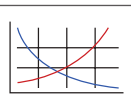

M = Metric (mm)

WARNING Exceeding weight capacity for machine tool spindle and tool changer can cause machine damage and/or serious injury. To prevent:
 -Consult machine tool builder for machine's weight limitations.
 -Refer to example on page B10-M: 11 for calculating tool assembly weight.
 Factory technical assistance is also available for specific applications through our Application Engineering department. *email: engineering.eu@alliedmachine.com*

WARNING Tool failure can cause serious injury. To prevent:
 -Do not exceed recommended 10xD length-to-diameter ratio or exceed 4 total components (including shank).
 -When using Alu-Line® components, do not exceed recommended 5xD length-to-diameter ratio.
 -When using tool steel components, do not exceed recommended 6xD length-to-diameter ratio.
 -When using heavy metal components, do not exceed recommended 8xD length-to-diameter ratio.
 -When using a carbide shank, do not exceed recommended 9xD length-to-diameter ratio.
 -When using a NOVITECH® module, do not exceed recommended 10xD length-to-diameter ratio.
 -Refer to examples on pages B10-M: 8-10 for calculating length-to-diameter ratio.
 Factory technical assistance is available for your specific applications through our Application Engineering department. *email: engineering.eu@alliedmachine.com*

BT Master Shanks (JIS B 6339)

Balanced

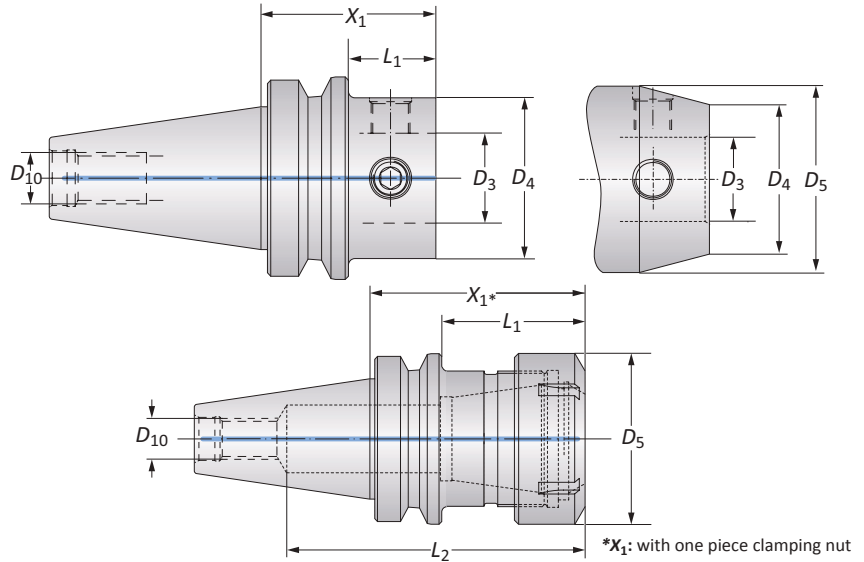

Taper Size	Connection	Shank					Weight	Part No.
		$D_4 D_3$	X_1	L_1	L_2	D_5		
30	40 - 22	40.00	18.00	-	-	M12 x 1.75	0.50 (kg)	327012
30	50 - 28	46.00	-	-	-	M12 x 1.75	0.60 (kg)	327013
40	40 - 22	46.00	19.00	-	-	M16 x 2	1.10 (kg)	327016
40	50 - 28	54.00	27.00	-	-	M16 x 2	1.20 (kg)	327019
40	63 - 36	64.00	-	-	-	M16 x 2	1.50 (kg)	327020
40	ER 40	70.00	43.00	104.00	63.00	M16 x 2	1.20 (kg)	259081*
50	50 - 28	65.00	26.80	-	-	M24 x 3	3.90 (kg)	327021
50	50 - 28	205.00	166.80	-	60.00	M24 x 3	7.00 (kg)	327029**
50	50 - 28	205.00	166.80	-	49.50	M24 x 3	5.90 (kg)	327036**
50	63 - 36	75.00	36.80	-	-	M24 x 3	4.20 (kg)	327022
50	63 - 36	225.00	186.80	-	78.00	M24 x 3	9.90 (kg)	327030**
50	63 - 36	225.00	186.80	-	-	M24 x 3	7.80 (kg)	327037**
50	80 - 36	75.00	36.80	-	-	M24 x 3	4.70 (kg)	327023
50	80 - 36	275.00	236.80	-	90.00	M24 x 3	14.80 (kg)	327031**
50	80 - 36	275.00	236.80	-	-	M24 x 3	14.80 (kg)	327038**
50	100 - 56	90.00	-	-	-	M24 x 3	5.50 (kg)	327024
50	100 - 56	290.00	251.80	-	-	M24 x 3	17.30 (kg)	327032**
50	ER 40	80.00	41.80	135.00	63.00	M24 x 3	3.80 (kg)	259082*

NOTE: Balanced refers to a specific residual imbalance of ≤ 4.00 gmm/kg.

*Balanced without clamping nut.

**Available upon request.

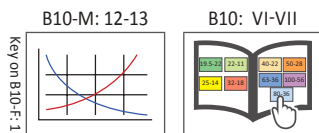

Ⓜ = Metric (mm)

⚠ WARNING Exceeding weight capacity for machine tool spindle and tool changer can cause machine damage and/or serious injury. To prevent:
 -Consult machine tool builder for machine's weight limitations.
 -Refer to example on page B10-M: 11 for calculating tool assembly weight.
 Factory technical assistance is also available for specific applications through our Application Engineering department. *email: engineering.eu@alliedmachine.com*

⚠ WARNING Tool failure can cause serious injury. To prevent:
 -Do not exceed recommended 10xD length-to-diameter ratio or exceed 4 total components (including shank).
 -When using Alu-Line® components, do not exceed recommended 5xD length-to-diameter ratio.
 -When using tool steel components, do not exceed recommended 6xD length-to-diameter ratio.
 -When using heavy metal components, do not exceed recommended 8xD length-to-diameter ratio.
 -When using a carbide shank, do not exceed recommended 9xD length-to-diameter ratio.
 -When using a NOVITECH® module, do not exceed recommended 10xD length-to-diameter ratio.
 -Refer to examples on pages B10-M: 8-10 for calculating length-to-diameter ratio.
 Factory technical assistance is available for your specific applications through our Application Engineering department. *email: engineering.eu@alliedmachine.com*

NMTB Master Shanks

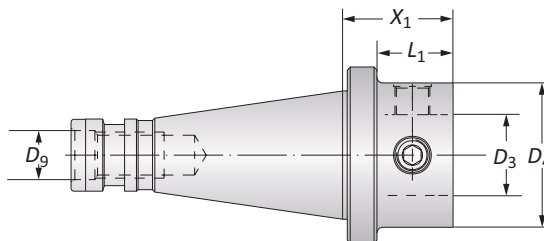

Taper Size	Connection		Shank			Weight	Part No.
	D_4 D_3	X_1	L_1	D_9			
M	40	50 - 28	38.00	26.40	$\frac{5}{8}$ - 11	1.30 (kg)	132022T004498
	40	63 - 36	48.00	36.40	$\frac{5}{8}$ - 11	1.50 (kg)	132066T004498
	50	50 - 28	42.00	26.80	1 - 8	3.00 (kg)	132022T004480
	50	63 - 36	52.00	36.80	1 - 8	3.50 (kg)	132066T004480
	50	80 - 36	52.00	36.80	1 - 8	4.00 (kg)	132088T004480
	50	100 - 56	90.00	74.80	1 - 8	4.90 (kg)	132076T004480

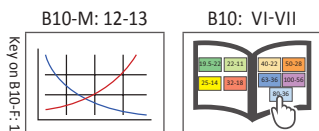

M = Metric (mm)

WARNING Exceeding weight capacity for machine tool spindle and tool changer can cause machine damage and/or serious injury. To prevent:
 -Consult machine tool builder for machine's weight limitations.
 -Refer to example on page B10-M: 11 for calculating tool assembly weight.
 Factory technical assistance is also available for specific applications through our Application Engineering department. *email: engineering.eu@alliedmachine.com*

WARNING Tool failure can cause serious injury. To prevent:
 -Do not exceed recommended 10xD length-to-diameter ratio or exceed 4 total components (including shank).
 -When using Alu-Line® components, do not exceed recommended 5xD length-to-diameter ratio.
 -When using tool steel components, do not exceed recommended 6xD length-to-diameter ratio.
 -When using heavy metal components, do not exceed recommended 8xD length-to-diameter ratio.
 -When using a carbide shank, do not exceed recommended 9xD length-to-diameter ratio.
 -When using a NOVITECH® module, do not exceed recommended 10xD length-to-diameter ratio.
 -Refer to examples on pages B10-M: 8-10 for calculating length-to-diameter ratio.
 Factory technical assistance is available for your specific applications through our Application Engineering department. *email: engineering.eu@alliedmachine.com*

DIN 2080 Master Shanks

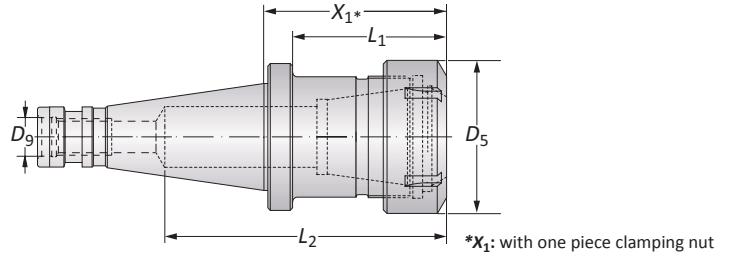
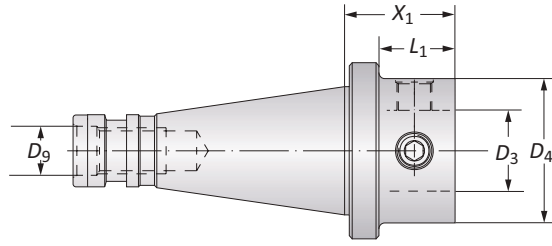

Taper Size	Connection	Shank					Weight	Part No.	
	$D_4 D_3$	X_1	L_1	L_2	D_5	D_9			
m	40	50 - 28	38.00	26.40	-	-	M16 x 2	1.30 (kg)	132022T010229
	40	63 - 36	48.00	36.40	-	-	M16 x 2	1.50 (kg)	132066T010229
	50	50 - 28	42.00	26.80	-	-	M24 x 3	3.00 (kg)	132022T003704
	50	63 - 36	52.00	36.80	-	-	M24 x 3	3.50 (kg)	132066T003704
	50	80 - 36	52.00	36.80	-	-	M24 x 3	4.00 (kg)	132088T003704
	50	100 - 56	90.00	74.80	-	-	M24 x 3	4.90 (kg)	132076T003704
	50	ER 40	80.00	64.80	134.00	63.00	M24 x 3	3.30 (kg)	259084

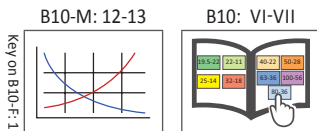

m = Metric (mm)

WARNING Exceeding weight capacity for machine tool spindle and tool changer can cause machine damage and/or serious injury. To prevent:
 -Consult machine tool builder for machine's weight limitations.
 -Refer to example on page B10-M: 11 for calculating tool assembly weight.
 Factory technical assistance is also available for specific applications through our Application Engineering department. *email: engineering.eu@alliedmachine.com*

WARNING Tool failure can cause serious injury. To prevent:
 -Do not exceed recommended 10xD length-to-diameter ratio or exceed 4 total components (including shank).
 -When using Alu-Line® components, do not exceed recommended 5xD length-to-diameter ratio.
 -When using tool steel components, do not exceed recommended 6xD length-to-diameter ratio.
 -When using heavy metal components, do not exceed recommended 8xD length-to-diameter ratio.
 -When using a carbide shank, do not exceed recommended 9xD length-to-diameter ratio.
 -When using a NOVI^{TECH}® module, do not exceed recommended 10xD length-to-diameter ratio.
 -Refer to examples on pages B10-M: 8-10 for calculating length-to-diameter ratio.
 Factory technical assistance is available for your specific applications through our Application Engineering department. *email: engineering.eu@alliedmachine.com*

DIN 1806 Morse Taper Master Shanks | R8 Master Shanks

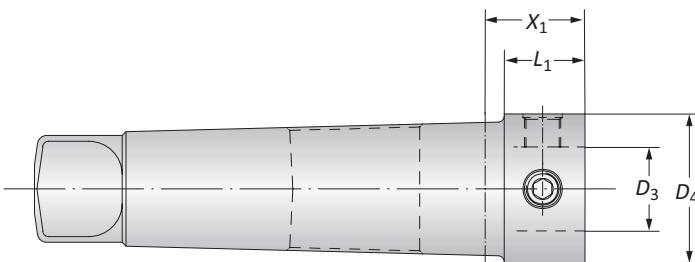

DIN 1806 Master Shanks

Morse Taper Size	Connection $D_4 D_3$	Shank		Weight	Part No.
		X_1	L_1		
4	50 - 28	43.00	36.50	1.10 (kg)	132022T003590
5	50 - 28	33.00	26.70	1.80 (kg)	132022T003920
5	63 - 36	53.00	46.70	2.20 (kg)	132066T003920

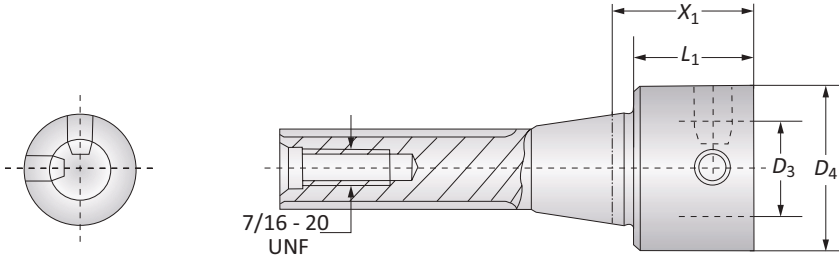

Connection $D_4 D_3$	Shank		Weight	Part No.
	X_1	L_1		
50 - 28	45.00	36.00	1.00 (kg)	132022T007166
63 - 36	60.00	51.00	1.30 (kg)	132066T007166

B10-M: 12-13

B10: VI-VII

Key on B10-F: 1

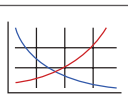

 = Metric (mm)

WARNING Exceeding weight capacity for machine tool spindle and tool changer can cause machine damage and/or serious injury. To prevent:
 -Consult machine tool builder for machine's weight limitations.
 -Refer to example on page B10-M: 11 for calculating tool assembly weight.
 Factory technical assistance is also available for specific applications through our Application Engineering department. *email: engineering.eu@alliedmachine.com*

WARNING Tool failure can cause serious injury. To prevent:
 -Do not exceed recommended 10xD length-to-diameter ratio or exceed 4 total components (including shank).
 -When using Alu-Line® components, do not exceed recommended 5xD length-to-diameter ratio.
 -When using tool steel components, do not exceed recommended 6xD length-to-diameter ratio.
 -When using heavy metal components, do not exceed recommended 8xD length-to-diameter ratio.
 -When using a carbide shank, do not exceed recommended 9xD length-to-diameter ratio.
 -When using a NOVITECH® module, do not exceed recommended 10xD length-to-diameter ratio.
 -Refer to examples on pages B10-M: 8-10 for calculating length-to-diameter ratio.
 Factory technical assistance is available for your specific applications through our Application Engineering department. *email: engineering.eu@alliedmachine.com*

Accessories

Coolant Adapter Sets | Service Keys | ISO 15488 (DIN 6499-B) Collet Chuck Accessories

Coolant Adapter Sets

HSK Shank Size	Thread	Part No.
32	M10 x 1.5 x 1.0	262002
40	M12 x 1.75 x 1.0	262003
50	M16 x 2 x 1.0	262004
63	M18 x 2.5 x 1.0	262005
80	M20 x 2.5 x 1.5	262006
100	M24 x 3 x 1.5	262007

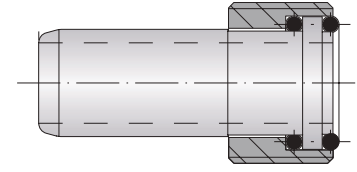

Service Keys

HSK Shank Size	D	Part No.
32	8.50	315234
40	10.50	315235
50	14.50	215726
63	16.50	215727*
80	18.00	415127
100	22.00	215728

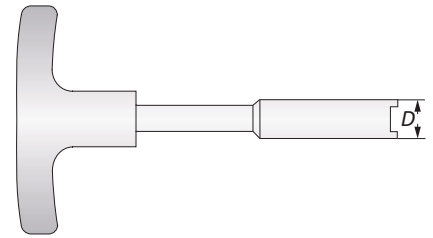

*Two piece

ISO 15488 (DIN 6499-B) One Piece Clamping Nut

Nominal Size	Clamping Nut		Part No.
	L ₁	D ₁	
m ER 40	25.50	63.00	215926

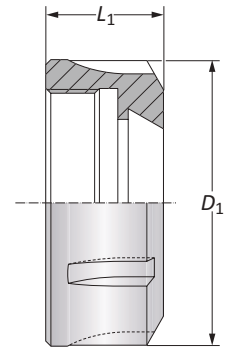

ISO 15488 (DIN 6499-B) Sealing Disk Clamping Nut

Nominal Size	Sealing Disk Clamping Nut		Part No.
	L ₁	D ₁	
m ER 40	34.00	63.00	278001

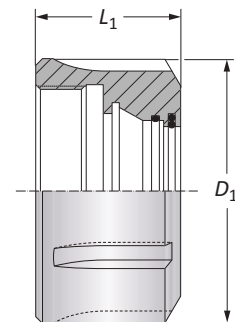

B10-M: 12-13

B10: VI-VII

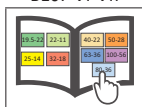
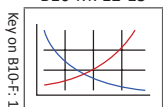

m = Metric (mm)

Accessories

ISO 15488 (DIN 6499-B) Collet Chuck Accessories

ISO 15488 (DIN6499-B) Collets

	Clamping Range		Collet		Part No.
	A	L_1	D_1		
m	15.00 - 14.00	46.00	40.00		071790
	18.00 - 17.00	46.00	40.00		071793
	20.00 - 19.00	46.00	40.00		071795
	23.00 - 22.00	46.00	40.00		071798

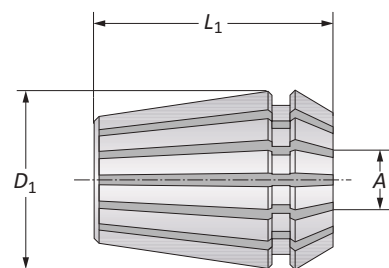

ISO 15488 (DIN 6499-B) Service Keys

	Service Key		Part No.
	Nominal Size	D	
m	ER 40	63.00	215931

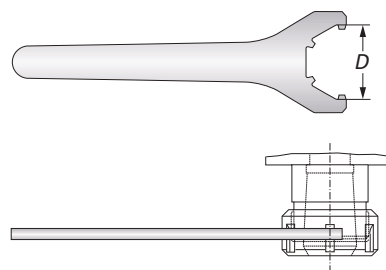

ISO 15488 (DIN 6499-B) Sealing Disks

	Clamping Range		Part No.
	A	D_1	
m	15.00 - 14.50		278029
	18.00 - 17.50		278035
	20.00 - 19.50		278039
	23.00 - 22.50		278045

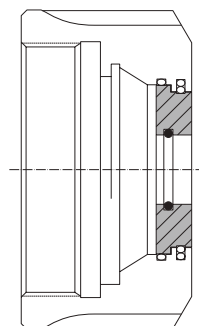

Application with clamping nuts and sealing disks when using central coolant feed:

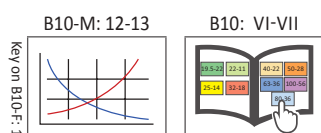
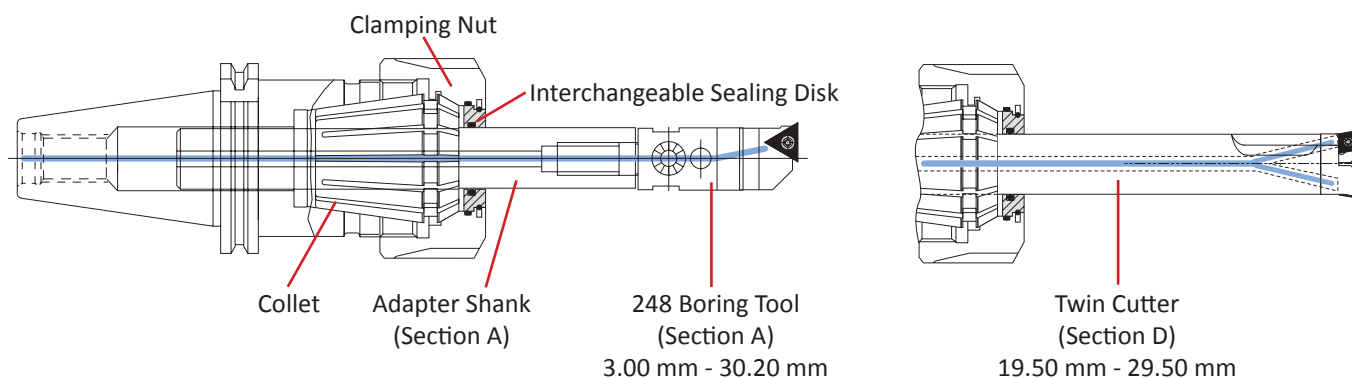

m = Metric (mm)

Accessories

Mounting Fixtures



Mounting Fixture		
Code	Type	Part No.
Basic Body*	-	098060
Adapter	30 Taper	098073
Adapter	40 Taper	098061
Adapter	50 Taper	098062
Adapter	HSK-A 32	098063
Adapter	HSK-A 40	098064
Adapter	HSK-A 50	098065
Adapter	HSK-A 63	098066
Adapter	HSK-A 80	098067
Adapter	HSK-A 100	098068
Adapter	PSC 50	098069
Adapter	PSC 63	098070
Adapter	PSC 80	098071

*Basic body and adapters sold separately.

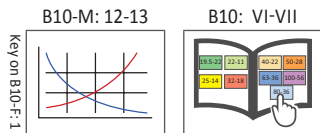

Ⓜ = Metric (mm)

⚠ WARNING Exceeding weight capacity for machine tool spindle and tool changer can cause machine damage and/or serious injury. To prevent:
 -Consult machine tool builder for machine's weight limitations.
 -Refer to example on page B10-M: 11 for calculating tool assembly weight.
 Factory technical assistance is also available for specific applications through our Application Engineering department. *email: engineering.eu@alliedmachine.com*

⚠ WARNING Tool failure can cause serious injury. To prevent:
 -Do not exceed recommended 10xD length-to-diameter ratio or exceed 4 total components (including shank).
 -When using Alu-Line® components, do not exceed recommended 5xD length-to-diameter ratio.
 -When using tool steel components, do not exceed recommended 6xD length-to-diameter ratio.
 -When using heavy metal components, do not exceed recommended 8xD length-to-diameter ratio.
 -When using a carbide shank, do not exceed recommended 9xD length-to-diameter ratio.
 -When using a NOVITECH® module, do not exceed recommended 10xD length-to-diameter ratio.
 -Refer to examples on pages B10-M: 8-10 for calculating length-to-diameter ratio.
 Factory technical assistance is available for your specific applications through our Application Engineering department. *email: engineering.eu@alliedmachine.com*

Guaranteed Test / Demo Application Form

Distributor PO #	
------------------	--

The following must be filled out completely before your test will be considered

IMPORTANT: For processing, send purchase order to your Allied Field Sales Engineer (FSE). Please clearly mark the paperwork as "Test Order."

Distributor Information

Company Name: _____
 Contact: _____
 Account Number: _____
 Phone: _____
 Email: _____

End User Information

Company Name: _____
 Contact: _____
 Industry: _____
 Phone: _____
 Email: _____

Current Process

List all tooling, coatings, substrates, speeds and feeds, tool life, and any problems you are experiencing

Test Objective

List what would make this a successful test (i.e. penetration rate, finish, tool life, hole size, etc.)

Application Information

Hole Diameter: _____ in/mm	Tolerance: _____	Material: _____ (4150, A36, cast iron, etc.)
Pre-existing Diameter: _____ in/mm	Depth of Cut: _____ in/mm	Hardness: _____ (BHN, Rc)
Required Finish: _____ RMS	State: _____	(Casting, hot rolled, forging)

Machine Information

Machine Type: _____ (Lathe, screw machine, machine center, etc.)	Builder: _____ (Haas, Mori Seiki, etc.)	Model #: _____
Shank Required: _____ (CAT50, Morse taper, etc.)		Power: _____ HP/KW
Rigidity: _____	Orientation: _____	Tool Rotating: _____
<input type="checkbox"/> Excellent	<input type="checkbox"/> Vertical	<input type="checkbox"/> Yes
<input type="checkbox"/> Good	<input type="checkbox"/> Horizontal	<input type="checkbox"/> No
<input type="checkbox"/> Poor		Thrust: _____ lbs/N

Coolant Information

Coolant Delivery: _____ (Through tool, flood)	Coolant Pressure: _____ PSI / bar
Coolant Type: _____ (Air mist, oil, synthetic, water soluble, etc.)	Coolant Volume: _____ GPM / LPM

Requested Tooling

QTY	Item Number

QTY	Item Number

engineering.eu@alliedmachine.com

Allied Machine & Engineering Co. (Europe) Ltd
 93 Vantage Point, Pensnett Estate,
 Kingswinford, DY6 7FR, United Kingdom

+44 (0)1384 400 900
www.alliedmachine.com



ALLIED MACHINE & ENGINEERING



WOHLHAUPTER®
 Holmaking Solutions for Today's Manufacturing



**ALLIED MACHINE
& ENGINEERING**

Warranty Information



Allied Machine & Engineering (“Allied Machine”) warrants to original equipment manufacturers, distributors, industrial and commercial users of its products for one year from the original date of sale that each new product manufactured or supplied by Allied Machine shall be free from defects in material and workmanship.

Allied Machine’s sole and exclusive obligation under this warranty is limited to, at its option, without additional charge, replacing or repairing this product or issuing a credit. For this warranty to be applied, the product must be returned freight prepaid to the plant designated by an Allied Machine representative and which, upon inspection, is determined by Allied Machine to be defective in material and workmanship.

Complete information as to operating conditions, machine, setup, and the application of cutting fluid should accompany any product returned for inspection. This warranty shall not apply to any Allied Machine products which have been subjected to misuse, abuse, improper operating conditions, improper machine setup or improper application of cutting fluid or which have been repaired or altered if such repair or alteration, in the judgement of Allied Machine, would adversely affect the performance of the product.

THIS WARRANTY IS IN LIEU OF ALL OTHER WARRANTIES, EXPRESS OR IMPLIED, INCLUDING ANY IMPLIED WARRANTY OF MERCHANTABILITY OR FITNESS FOR A PARTICULAR PURPOSE. Allied Machine shall have no liability or responsibility for any claim, whether in contract, tort or otherwise, for any loss or damage arising out of, connected with, or resulting from the manufacture, sale, delivery or use of any product sold hereunder, in excess of the cost of replacement or repair as provided herein.

Allied Machine shall not be liable in contract or in tort (including, without limitation, negligence, strict liability or otherwise) for economic losses of any kind or for any special, incidental, indirect, consequential, punitive or exemplary damages arising in any way out of the performance of, or failure to perform this agreement.

ALL PRICES, DELIVERIES, DESIGNS, AND MATERIALS ARE SUBJECT TO CHANGE WITHOUT NOTICE.



Allied Machine & Engineering Co. Europe Ltd. is registered to ISO 9001:2015 by bsi.



Allied Machine & Engineering is registered to ISO 9001:2015 by DQS



Wohlhaupter GmbH is registered to ISO 9001:2015 by GA TECHNIC

Europe

Allied Machine & Engineering Co. (Europe) Ltd.

93 Vantage Point
Pensnett Estate
Kingswinford
West Midlands
DY6 7FR England

Phone:

+44 (0) 1384.400900

Wohlhaupter® GmbH

Maybachstrasse 4
Postfach 1264
72636 Frickenhausen
Germany

Phone:

+49 (0) 7022.408.0

United States

Allied Machine & Engineering

120 Deeds Drive
Dover OH 44622
United States

Phone:

+1.330.343.4283

Toll Free USA and Canada:

800.321.5537

Toll Free USA and Canada:

800.223.5140

Allied Machine & Engineering

485 W Third Street
Dover OH 44622
United States

Phone:

+1.330.343.4283

Toll Free USA and Canada:

800.321.5537

Asia

Wohlhaupter® India Pvt. Ltd.

B-23, 3rd Floor
B Block Community Centre
Janakpuri, New Delhi - 110058
India

Phone:

+91 (0) 11.41827044

Your local Allied Machine representative:

www.alliedmachine.com

Allied Machine & Engineering Co. (Europe) Ltd is registered to **ISO 9001:2015** by bsi.

Allied Machine & Engineering is registered to **ISO 9001:2015** by DQS

Wohlhaupter GmbH is registered to **ISO 9001:2015** by QTA TECHNIC

