



**ALLIED MACHINE
& ENGINEERING**

WOHLHAUPTER®

Holemaking Solutions for Today's Manufacturing



Drilling



Reaming



Burnishing



Threading



Specials



Wohlhaupter®

► *BORING*

Fine Boring Tools

WOHLHAUPTER®

SECTION

B10-B

Fine Boring

Wohlhaupter® Fine Boring

410 | 464 | 364 | 564 | 310 | 537

► **Diameter Range:** 20.00 mm - 205.00 mm



NOTE: 3E^{TECH+} adjustment accuracy of 0.001 mm on diameter.

NOTE: Internal digital and vernier adjustment accuracy of 0.002 mm on diameter.

Boring has never been more exciting.

Wohlhaupter's fine boring systems are offered in both vernier and easy-to-read digital readout boring heads and cassettes. The lightweight Alu-Line serrated tool bodies reduce weight on the machine spindle.

Digital 3E^{TECH+} Boring Heads

- 410 / 464 fine boring heads
- 410 Ø 20.00 mm - 29.00 mm
- 464 Ø 29.00 mm - 205.00 mm

Balanced Analogue Boring Heads

- 364 / 464 fine boring heads
- 364 Ø 20.00 mm - 29.50 mm
- 464 Ø 29.00 mm - 205.00 mm

Balanced Digital Boring Heads

- 564 fine boring heads
- Ø 50.00 mm - 205.00 mm

Analogue Boring Heads

- 310 fine boring heads
- Ø 20.00 mm - 205.00 mm

Analogue and Digital Cassettes

- 537 fine boring cassettes
- Ø 100.00 mm - 205.00 mm

Applicable Industries



Aerospace



Agriculture



Automotive



Firearms



General
Machining



Oil & Gas



Renewable
Energy

Your safety and the safety of others is very important. This catalogue contains important safety messages. Always read and follow all safety precautions.



This triangle is a safety hazard symbol. It alerts you to potential safety hazards that can cause tool failure and serious injury.

When you see this symbol in the catalogue, look for a related safety message that may be near this triangle or referred to in the nearby text.

There are safety signal words also used in the catalogue. Safety messages follow these words.

WARNING

WARNING (shown above) means that failure to follow the precautions in this message could result in tool failure and serious injury.

NOTICE means that failure to follow the precautions in this message could result in damage to the tool or machine but not result in personal injury.

NOTE and **IMPORTANT** are also used. These are important that you read and follow but are not safety-related.

Visit www.alliedmachine.com for the most up-to-date information and procedures.

Reference Icons

The following icons will appear throughout the catalogue to help you navigate between products.

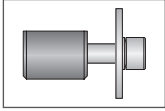

Clamping Elements

For use with insert holders and boring heads

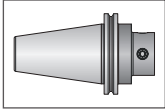

Shanks

A variety of shanks for different machines

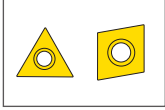

Inserts

For use with insert holder boring heads and boring bars using indexable inserts

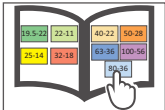

MVS Connection Colour Guide

Detailed instructions and information regarding the MVS connection(s)

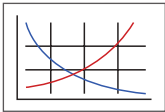

Recommended Cutting Data

Speed and feed recommendations for optimum and safe boring



Through Coolant Option

Indicates that the product is through coolant

410 and 464 Digital 3E^{TECH+}

Product Overview	2 - 3
410 Digital 3E ^{TECH+} Boring Heads	4
464 Balance Digital 3E ^{TECH+} Boring Heads	5 - 6
Insert Holders	7
Accessories	8

364 and 464 Balance Analogue

Product Overview	10 - 11
364 and 464 Balance Analogue Boring Heads	12
464 Balance Analogue Boring Heads	13
Insert Holders	14
Accessories	15

564 Balance Digital

Product Overview	16 - 17
564 Balance Digital Boring Heads	18 - 19
Insert Holders	20
Accessories	21

310 Analogue

Product Overview	22 - 23
310 Analogue Boring Heads	24 - 25
Serrated Shims Insert Holders	26
Accessories	27

537 Cassettes

Product Overview	28 - 29
537 Analogue Cassettes	30
537 Digital 3E ^{TECH+} Cassettes	31
Serrated Tool Bodies Insert Holders	32
Accessories	33

Series	Diameter Range
	Metric (mm)
410	20.00 - 29.00
464	29.00 - 205.00
364	20.00 - 29.50
564	50.00 - 205.00
310	20.00 - 205.00
537	100.00 - 205.00

410 and 464 Product Overview



410 and 464 Digital 3E^{TECH+} FINE BORING

Make easy diameter adjustments with our 3E^{TECH+} digital readout module.

Wohlhaupter® 410 and 464 balance digital boring heads are equipped with a 3E^{TECH+} docking port for easy digital adjustments. Boring heads from 29.00 mm offer precision boring with automatic balancing. Our boring heads are specifically engineered to minimise the residual imbalance produced by insert holder displacement. Wohlhaupter Alu-Line boring heads, ranging from 65.00 mm, offer a lightweight aluminium design with a wear-resistant coating that reduces weight on the spindle up to 50%. The insert holder can also be rotated for reverse machining jobs.

- 410 diameter range: 20.00 mm - 29.00 mm.
- 464 balance diameter range: 29.00 mm - 205.00 mm.
- 464 balance Alu-Line diameter range: 65.00 mm - 205.00 mm.
 - Special coating on Alu-Line for wear-resistant surface.
 - Alu-Line body reduces tool weight by 50%, reducing stress on the spindle.
- Through coolant.
- 3E^{TECH+} diameter adjustment of 0.001 mm.
- Vernier diameter adjustment of 0.002 mm.
- Internal balancing improves tool life and surface finish.
- Insert holder can be rotated for back boring jobs.
- Max cutting speed: 1,700 M/min.

Highly accurate adjustments through *vernier* scale



NOTE: 3E^{TECH+} adjustment accuracy of 0.001 mm on diameter.
NOTE: Vernier adjustment accuracy of 0.002 mm on diameter.

Versatile 3E^{TECH+} digital readout compatible with other boring tools

IMPORTANT: Max spindle speed refers to maximum possible speed for an individual boring head and is not a recommended parameter. Refer to page B10-M: 12 for recommended application-specific parameters. Factory technical assistance is available for your specific applications through our Application Engineering department.
email: engineering.eu@alliedmachine.com

WOHLHAUPTER® 410 and 464 DIGITAL 3E^{TECH+} **BORING HEADS**

Wohlhaupter 3E^{TECH+}

Improve productivity and quality with the Wohlhaupter 3E^{TECH+} external digital readout module. The 3E^{TECH+} docks onto boring heads and cassettes that offer the 3E^{TECH+} port to make easy diameter adjustments at the machine.

- Make quick and easy micron-accurate diameter adjustments.
- Easy-to-read digital display shows exact diameter adjustments.
- 3E^{TECH+} screen will auto-rotate to match orientation of the display module.
- Toggle between imperial and metric to accommodate all applications.
- Adjustments of 0.002 mm on diameter.
- Designed to be removed from boring tool before operation (if forgotten 3E^{TECH+} will fall off at 500 RPM).
- Water and dust resistant IP 56.
- Coolant and chip resistant.
- 3E^{TECH+} will automatically turn off after 30 seconds of not using.
- Adjustment setting is saved directly in the respective tool, even if the digital display is removed.
- WEEE-Reg.-Nr. DE 15820388.



High-production fine boring



Easy diameter adjustment with 3E^{TECH+}



Self-balancing 464 boring heads

410 & 464 BORING HEADS WITH 3E ^{TECH+}		
	Diameter Range	Part No.
m	20.00 - 24.50	410001
	24.50 - 29.00	410002
	29.00 - 38.00	464003
	38.00 - 50.00	464004
	50.00 - 65.50	464005
	65.00 - 83.00	464006
	82.00 - 103.00	464007
	100.00 - 130.00	464008
	125.00 - 167.50	464009
	162.50 - 205.00	464010



NOTE: 3E^{TECH+} adjustment accuracy of 0.001 mm on diameter.

NOTE: Vernier adjustment accuracy of 0.002 mm on diameter.

IMPORTANT: Max spindle speed refers to maximum possible speed for an individual boring head and is not a recommended parameter. Refer to page B10-M: 12 for recommended application-specific parameters. Factory technical assistance is available for your specific applications through our Application Engineering department.
email: engineering.eu@alliedmachine.com

410 Digital 3E^{TECH+} Boring Heads

Diameter Range: 20.00 mm - 29.00 mm



Form 101

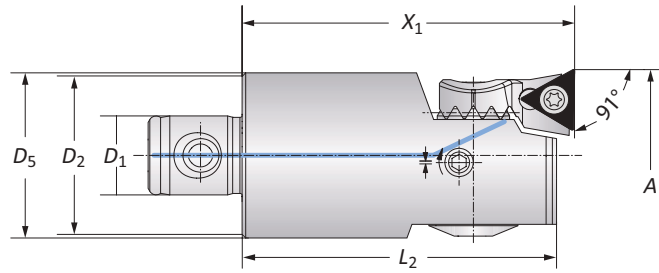

Form 20

410 Digital 3E^{TECH+} Boring Heads

MVS Connection	Boring Range	Boring Head				Weight	Insert Form	Part No.	
		D_2 D_1	A	X_1	L_2			D_5	Insert Holder
m	19 - 11	20.00 - 24.50	46.00	43.00	-	0.09 (kg)	20*	364077	410001
	22 - 11	24.50 - 29.00	46.00	43.50	23.00	0.13 (kg)	20	210059	410002
	22 - 11	24.50 - 29.00	46.00	43.50	23.00	0.13 (kg)	101	210069	410002

*Not suitable for indexable inserts with a radius of 0.80 mm.

NOTE: 3E^{TECH+} module, charging unit, insert holders, and inserts sold separately.

3E^{TECH+} Digital Readout Module

Part No.	Charging Unit*
536015	536016

NOTE: WEEE-Reg.-Nr. DE 15820388

*Charging unit sold separately.



NOTE: 3E^{TECH+} adjustment accuracy of 0.001 mm on diameter.

Key on B10-B: 1

B10-M: 12-13

B10-F

B10: VI-VII

m = Metric (mm)

IMPORTANT: Max spindle speed refers to maximum possible speed for an individual boring head and is not a recommended parameter. Refer to page B10-M: 12 for recommended application-specific parameters. Factory technical assistance is available for your specific applications through our Application Engineering department.
 email: engineering.eu@alliedmachine.com

464 Balance Digital 3E^{TECH+} Boring Heads

Diameter Range: 29.00 mm - 65.50 mm



Form 101

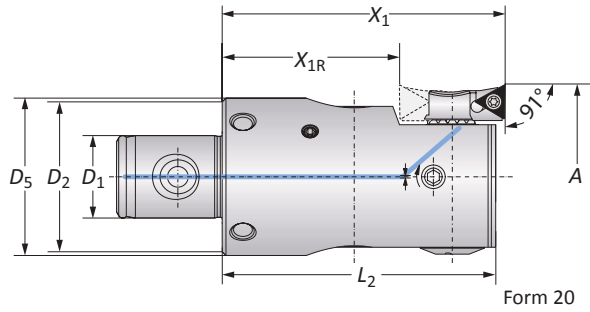

Form 20

464 Balance Digital 3E^{TECH+} Boring Heads

MVS Connection	Boring Range	Boring Head					Weight	Insert Form	Part No.	
		D_2 D_1	A	X_1	X_{1R}	L_2			D_5	Insert Holder
m	25 - 14	29.00 - 38.00	56.00	-	53.50	27.00	0.21 (kg)	20	210059	464003
	25 - 14	29.00 - 38.00	56.00	-	53.50	27.00	0.21 (kg)	101	210069	464003
	32 - 18	38.00 - 50.00	66.00	38.00	63.50	34.00	0.41 (kg)	20	264051	464004
	32 - 18	38.00 - 50.00	66.00	38.00	63.50	34.00	0.41 (kg)	101	264077	464004
	40 - 22	50.00 - 65.50	75.00	47.00	72.50	42.00	0.80 (kg)	20	210052	464005
	40 - 22	50.00 - 65.50	75.00	47.00	72.50	42.00	0.80 (kg)	101	210062	464005

NOTE: X_{1R} = rotated insert holder for reverse machining.

NOTE: 3E^{TECH+} module, charging unit, insert holders, and inserts sold separately.

3E^{TECH+} Digital Readout Module

Part No.	Charging Unit*
536015	536016

NOTE: WEEE-Reg.-Nr. DE 15820388

*Charging unit sold separately.



NOTE: 3E^{TECH+} adjustment accuracy of 0.001 mm on diameter.

B10-M: 12-13

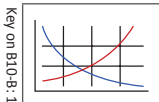

B10-F

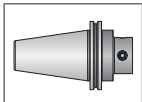

B10: VI-VII

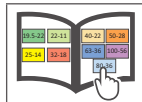

m = Metric (mm)

IMPORTANT: Max spindle speed refers to maximum possible speed for an individual boring head and is not a recommended parameter. Refer to page B10-M: 12 for recommended application-specific parameters. Factory technical assistance is available for your specific applications through our Application Engineering department.
email: engineering.eu@alliedmachine.com

464 Balance Digital Boring Heads with 3E^{TECH+}

Alu-Line | Diameter Range: 65.00 mm - 205.00 mm



Form 101

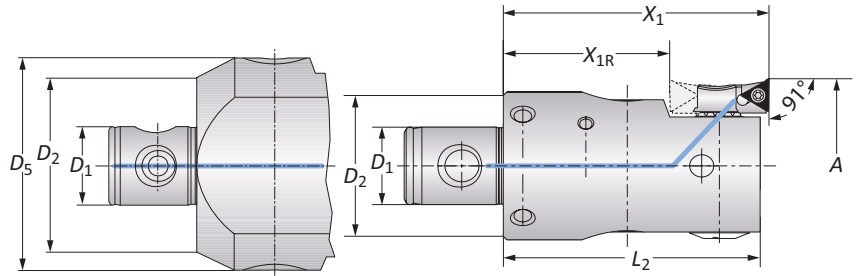

Form 20

464 Balance Alu-Line Digital 3E^{TECH+} Boring Heads

MVS Connection	Boring Range	Boring Head					Weight	Insert Form	Part No.	
		D_2 D_1	A	X_1	X_{1R}	L_2			D_5	Insert Holder
	50 - 28	65.00 - 83.00	75.00	39.00	73.00	-	0.60 (kg)	20	210020	464006
	50 - 28	65.00 - 83.00	75.00	39.00	73.00	-	0.60 (kg)	101	210063	464006
	50 - 28	65.00 - 83.00	75.00	39.00	73.00	-	0.60 (kg)	103	210064	464006
	63 - 36	82.00 - 103.00	90.00	54.00	88.00	-	1.00 (kg)	20	210020	464007
	63 - 36	82.00 - 103.00	90.00	54.00	88.00	-	1.00 (kg)	101	210063	464007
	63 - 36	82.00 - 103.00	90.00	54.00	88.00	-	1.00 (kg)	103	210064	464007
	80 - 36	100.00 - 130.00	90.00	54.00	88.00	-	1.50 (kg)	20	210020	464008
m	80 - 36	100.00 - 130.00	90.00	54.00	88.00	-	1.50 (kg)	101	210063	464008
	80 - 36	100.00 - 130.00	90.00	54.00	88.00	-	1.50 (kg)	103	210064	464008
	80 - 36	125.00 - 167.50	90.00	54.00	88.00	100.00	1.90 (kg)	20	210020	464009
	80 - 36	125.00 - 167.50	90.00	54.00	88.00	100.00	1.90 (kg)	101	210063	464009
	80 - 36	125.00 - 167.50	90.00	54.00	88.00	100.00	1.90 (kg)	103	210064	464009
	80 - 36	162.50 - 205.00	90.00	54.00	88.00	135.00	2.50 (kg)	20	210020	464010
	80 - 36	162.50 - 205.00	90.00	54.00	88.00	135.00	2.50 (kg)	101	210063	464010
	80 - 36	162.50 - 205.00	90.00	54.00	88.00	135.00	2.50 (kg)	103	210064	464010

NOTE: X_{1R} = rotated insert holder for reverse machining.

NOTE: 3E^{TECH+} module, insert holders, and inserts sold separately.

3E^{TECH+} Digital Readout Module

Part No.	Charging Unit*
536015	536016

NOTE: WEEE-Reg.-Nr. DE 15820388

*Charging unit sold separately.



NOTE: 3E^{TECH+} adjustment accuracy of 0.001 mm on diameter.

B10-M: 12-13

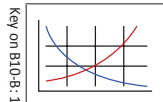

B10-F

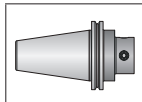

B10: VI-VII

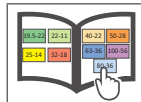

Key on B10-B: 1

m = Metric (mm)

IMPORTANT: Max spindle speed refers to maximum possible speed for an individual boring head and is not a recommended parameter. Refer to page B10-M: 12 for recommended application-specific parameters. Factory technical assistance is available for your specific applications through our Application Engineering department.
email: engineering.eu@alliedmachine.com

Insert Holders for Abrasive Materials

Diameter Range: 65.00 mm - 205.00 mm

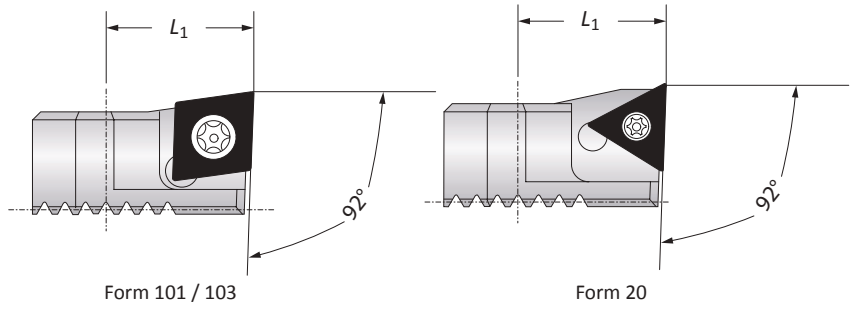
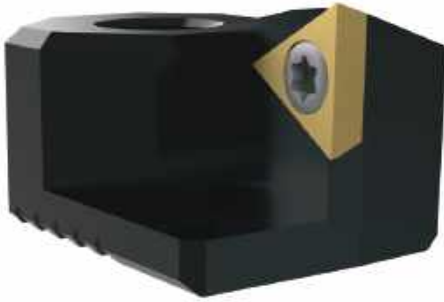

	Insert Holder				
	L_1	Weight	Insert Form	Part No.	
	65.00 - 205.00	18.00	0.03 (kg)	20	211061
	65.00 - 205.00	18.00	0.03 (kg)	101	211063
	65.00 - 205.00	18.00	0.03 (kg)	103	211065

NOTE: Insert holders used for abrasive materials to protect boring head against chip wash.

NOTE: When machining grey cast iron, we recommend using insert holders for abrasive materials with CBN inserts for optimised chip removal.

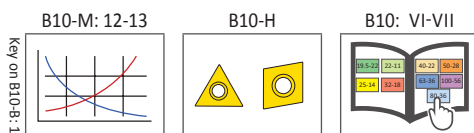

 = Metric (mm)
Inserts sold separately

Accessories

Screws | 3E^{TECH+} Accessories

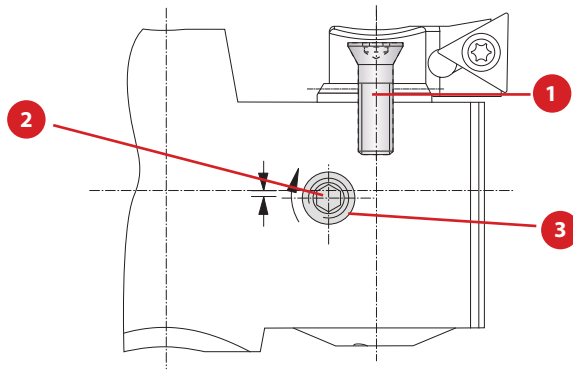

Screws

Boring Head	Part No.				
	1 Countersunk Screw	Countersunk Screw Service Key	2 Clamping Screw	Clamping Screw Service Key	3 Ball
410001	215323	T15 / H	410151	S2 / A	364270
410002	215338	T15 / H	410152	s2 / A	364270
464003	215338	T15 / H	364138	s2.5 / A	364139
464004	215338	T15 / H	115180	s2.5 / A	-
464005	215338	T15 / H	115505	s3 / B	-
464006	215462	T20 / H	315943	s4 / B	-
464007	215462	T20 / H	515178	s4 / B	-
464008	215462	T20 / H	515178	s4 / B	-
464009	215462	T20 / H	515178	s4 / B	-
464010	215462	T20 / H	515178	s4 / B	-

3E^{TECH+} Accessories

1 Charging Unit
Part No.
536016

NOTE: Charging unit sold separately from 3E^{TECH+}.



NOTE: 3E^{TECH+} adjustment accuracy of 0.001 mm on diameter.

3E^{TECH} Accessories (Old Display)

1 Sealing Ring	2 Battery CR2032
Part No.	Part No.
215483	515491

NOTE: Not required for 3E^{TECH+} (new display).

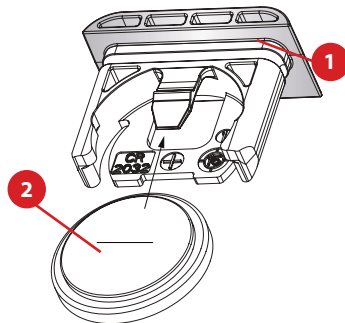

B10-M: 12-13

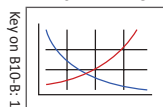

B10: VI-VII

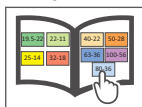

364 and 464 Product Overview

364 and 464 Balance Analogue FINE BORING

Analogue fine boring tools for high-production jobs

Wohlhaupter® 364 and 464 balance analogue boring heads offer precision boring with automatic balancing. Our boring heads are specifically engineered to minimise the residual imbalance produced by insert holder displacement. Wohlhaupter Alu-Line boring heads offer a lightweight aluminium design with a wear-resistant coating that reduces weight on the spindle up to 50% yet remains durable in challenging boring applications. The insert holder can also be rotated for reverse machining jobs.

- 364 balance diameter range: 20.00 mm - 29.50 mm.
- 464 balance diameter range: 29.00 mm - 205.00 mm.
- 464 balance Alu-Line diameter range: 65.00 mm - 205.00 mm.
 - Special coating on Alu-Line for wear-resistant surface.
 - Alu-Line body reduces tool weight by 50%, reducing stress on the spindle.
- Internal balancing improves tool life and surface finish.
- Through coolant.
- Vernier diameter adjustment of 0.002 mm.
- Insert holder can be rotated for back boring jobs.
- Max cutting speed: 1,000 M/min.



IMPORTANT: Max spindle speed refers to maximum possible speed for an individual boring head and is not a recommended parameter. Refer to page B10-M: 12 for recommended application-specific parameters. Factory technical assistance is available for your specific applications through our Application Engineering department.
email: engineering.eu@alliedmachine.com

WOHLHAUPTER® 464 BALANCE ANALOG **BORING HEADS**

ANALOGUE BORING HEAD PART NUMBER CONVERSION		
Diameter Range	Old Part No.	<i>UPDATED</i> Part No.
20.00 - 24.50	364030	<i>No Change</i>
24.50 - 29.50	364031	<i>No Change</i>
29.00 - 38.00	364032	464033
38.00 - 50.00	364033	464034
50.00 - 65.50	364034	464035
65.00 - 83.00	364045	464036
82.00 - 103.00	364046	464037
100.00 - 130.00	364047	464038
125.00 - 167.50	364048	464039
162.50 - 205.00	364049	464040

✓ High-production fine boring

✓ Easy diameter adjustment

✓ Self-balancing

✓ Imperial and metric

FEATURES AN **ENHANCED** CLAMPING MECHANISM FROM OUR TRUSTED LINE OF 564 BALANCE DIGITAL FINE BORING HEADS

Aluminium bodies with *wear-resistant* coating from 65.00 mm - 205.00 mm



Highly accurate adjustments through *vernier* scale



Equipped with *self-balancing* mechanism

364 and 464 Balance Analogue Boring Heads

Diameter Range: 20.00 mm - 65.50 mm



364
Form 101

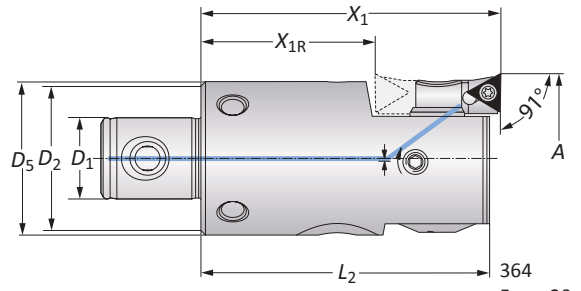
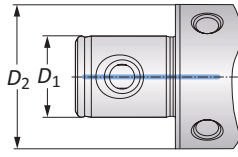

364
Form 20



464
Form 101

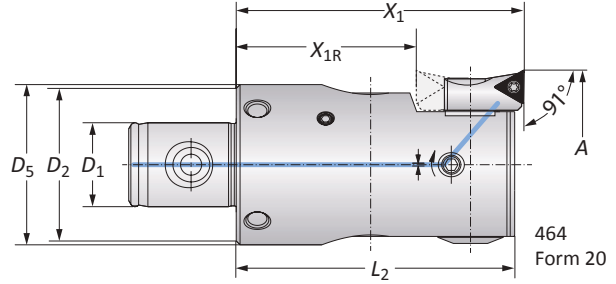

464
Form 20

364 and 464 Balance Analogue Boring Heads

MVS Connection	Boring Range	Boring Head					Weight	Insert Form	Part No.	
		$D_2 D_1$	A	X_1	X_{1R}	L_2			D_5	Insert Holder
	19 - 11	20.00 - 24.50	46.00	-	43.00	-	0.09 (kg)	20*	364077	364030
	22 - 11	24.50 - 29.50	46.00	-	43.50	23.00	0.15 (kg)	20	210059	364031
	22 - 11	24.50 - 29.50	46.00	-	43.50	23.00	0.15 (kg)	101	210069	364031
	25 - 14	29.00 - 38.00	56.00	-	53.50	27.00	0.20 (kg)	20	210059	464033
m	25 - 14	29.00 - 38.00	56.00	-	53.50	27.00	0.20 (kg)	101	210069	464033
	32 - 18	38.00 - 50.00	66.00	38.00	63.50	34.00	0.40 (kg)	20	264051	464034
	32 - 18	38.00 - 50.00	66.00	38.00	63.50	34.00	0.40 (kg)	101	264077	464034
	40 - 22	50.00 - 65.50	75.00	47.00	72.50	42.00	0.80 (kg)	20	210052	464035
	40 - 22	50.00 - 65.50	75.00	47.00	72.50	42.00	0.80 (kg)	101	210062	464035

*Not suitable for indexable inserts with a radius of 0.80 mm.

NOTE: X_{1R} = rotated insert holder for reverse machining.

NOTE: Insert holders and inserts sold separately.

B10-M: 12-13

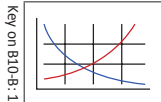

B10-F

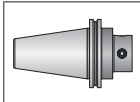

B10: VI-VII

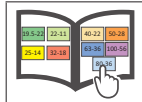

Key on B10-B: 1

m = Metric (mm)

IMPORTANT: Max spindle speed refers to maximum possible speed for an individual boring head and is not a recommended parameter. Refer to page B10-M: 12 for recommended application-specific parameters. Factory technical assistance is available for your specific applications through our Application Engineering department.
email: engineering.eu@alliedmachine.com

464 Balance Analogue Boring Heads

Alu-Line | Diameter Range: 65.00 mm - 205.00 mm



Form 101

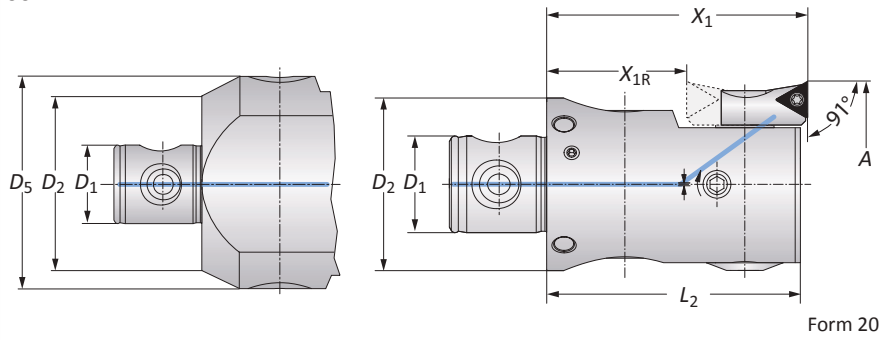

Form 20

464 Balance Analogue Alu-Line Boring Heads

MVS Connection	Boring Range	Boring Head				Weight	Insert Form	Part No.	
		D_2 D_1	A	X_1	X_{1R}			L_2	D_5
50 - 28	65.00 - 83.00	75.00	39.00	72.50	-	0.60 (kg)	20	210020	464036
50 - 28	65.00 - 83.00	75.00	39.00	72.50	-	0.60 (kg)	101	210063	464036
50 - 28	65.00 - 83.00	75.00	39.00	72.50	-	0.60 (kg)	103	210064	464036
63 - 36	82.00 - 103.00	90.00	54.00	87.50	-	1.00 (kg)	20	210020	464037
63 - 36	82.00 - 103.00	90.00	54.00	87.50	-	1.00 (kg)	101	210063	464037
63 - 36	82.00 - 103.00	90.00	54.00	87.50	-	1.00 (kg)	103	210064	464037
80 - 36	100.00 - 130.00	90.00	54.00	87.50	-	1.50 (kg)	20	210020	464038
80 - 36	100.00 - 130.00	90.00	54.00	87.50	-	1.50 (kg)	101	210063	464038
80 - 36	100.00 - 130.00	90.00	54.00	87.50	-	1.50 (kg)	103	210064	464038
80 - 36	125.00 - 167.50	90.00	54.00	87.50	100.00	1.90 (kg)	20	210020	464039
80 - 36	125.00 - 167.50	90.00	54.00	87.50	100.00	1.90 (kg)	101	210063	464039
80 - 36	125.00 - 167.50	90.00	54.00	87.50	100.00	1.90 (kg)	103	210064	464039
80 - 36	162.50 - 205.00	90.00	54.00	87.50	135.00	2.50 (kg)	20	210020	464040
80 - 36	162.50 - 205.00	90.00	54.00	87.50	135.00	2.50 (kg)	101	210063	464040
80 - 36	162.50 - 205.00	90.00	54.00	87.50	135.00	2.50 (kg)	103	210064	464040

NOTE: X_{1R} = rotated insert holder for reverse machining.

NOTE: Insert holders and inserts sold separately.

B10-M: 12-13

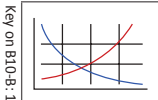

B10-F

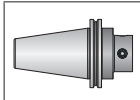

B10: VI-VII

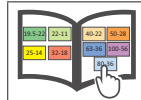

 = Metric (mm)

IMPORTANT: Max spindle speed refers to maximum possible speed for an individual boring head and is not a recommended parameter. Refer to page B10-M: 12 for recommended application-specific parameters. Factory technical assistance is available for your specific applications through our Application Engineering department.
 email: engineering.eu@alliedmachine.com

Insert Holders for Abrasive Materials

Diameter Range: 265.00 mm - 205.00 mm

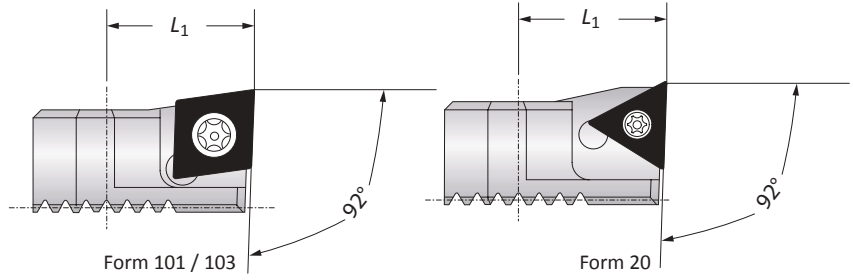

	Insert Holder			
Boring Range	L_1	Weight	Insert Form	Part No.
65.00 - 205.00	18.00	0.03 (kg)	20	211061
65.00 - 205.00	18.00	0.03 (kg)	101	211063
65.00 - 205.00	18.00	0.03 (kg)	103	211065

NOTE: Insert holders used for abrasive materials to protect boring head against chip wash.

NOTE: When machining grey cast iron, we recommend using insert holders for abrasive materials with CBN inserts for optimised chip removal.

B10-M: 12-13

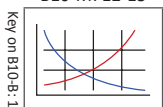

B10-H

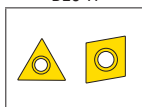

B10: VI-VII

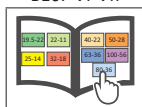

m = Metric (mm)

Inserts sold separately

Accessories

Screws

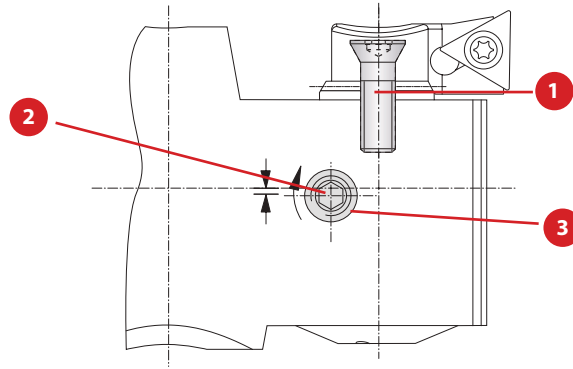

Boring Head	Part No.				
	1 Countersunk Screw	Countersunk Screw Service Key	2 Clamping Screw	Clamping Screw Service Key	3 Ball
364030	215323	T15 / H	364260	s2 / A	364270
364031	215338	T15 / H	364138	s2.5 / A	364139
464033	215338	T15 / H	364138	s2.5 / A	364139
464034	215338	T15 / H	115180	s2.5 / A	-
464035	215338	T15 / H	115505	s3 / B	-
464036	215462	T20 / H	315943	s4 / B	-
464037	215462	T20 / H	515178	s4 / B	-
464038	215462	T20 / H	515178	s4 / B	-
464039	215462	T20 / H	515178	s4 / B	-
464040	215462	T20 / H	515178	s4 / B	-

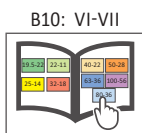
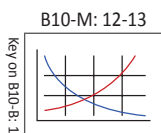

564 Balance Digital Product Overview

564 Balance Digital FINE BORING

Adjustable diameter for precise machining.

Wohlhaupter® digital 564 balance boring heads feature automatic balancing with an easy-to-read digital display. For diameter ranges above 65.00 mm, 564 boring heads are made of lightweight aluminium. 564 boring heads are specifically engineered to minimise the residual imbalance produced by insert holder displacement. Reverse boring applications can be achieved by rotating the insert holders.

Test the **engineered lightweight** boring head today.

- Diameter range: 50.00 mm - 205.00 mm.
- Alu-Line diameter range: 65.00 mm - 205.00 mm.
 - Special coating on Alu-Line for wear-resistant surface.
 - Alu-Line body reduces tool weight by 50%, reducing stress on the spindle.
- Digital readout advantage for diameter adjustments of 0.002 mm.
- Through coolant.
- Internal balancing improves tool life and surface finish.
- Insert holder can be rotated for back boring jobs.
- Max cutting speed: 2,000 M/min.
- Max coolant pressure: 40 bar.



Aluminium Boring Head
65.00 mm - 205.00 mm

Steel Boring Head
50.00 mm - 65.50 mm

NOTE: Metric items pictured.

NOTE: Digital adjustment accuracy of 0.002 mm on diameter.

IMPORTANT: Max spindle speed refers to maximum possible speed for an individual boring head and is not a recommended parameter. Refer to page B10-M: 12 for recommended application-specific parameters. Factory technical assistance is available for your specific applications through our Application Engineering department.
email: engineering.eu@alliedmachine.com

564 DIGITAL BORING HEAD

Balance with **NOVI^{TECH}**

Product:	Wohlhaupter 564 balance digital boring head with NOVI ^{TECH}	Measure	564 Balance Digital Boring Head with NOVI^{TECH}
Objectives:	0.005 mm concentricity over the length of two bores spaced 355.60 mm apart	RPM	430 RPM
Material:	Cast iron	Speed	352 SFM (107.28 m/min)
Hole Ø:	79.38 mm	Feed Rate	0.003 IPR (0.08 mm/rev)
Depth:	469.9 mm	Penetration Rate	1.29 IPM (33 mm/min)
Stock Removal:	0.80 mm on diameter		

- ▶ Boring head
564 series
Item No. 564045
- ▶ NOVI^{TECH} vibration dampening intermediate module
Item No. 519005
- ▶ Wohlhaupter boring insert:
Item No. 397239WHC79
(F103 04MN158 WHC79)

The balanced 564 digital boring head with the NOVI^{TECH} vibration damper module provided:

✓ **Precision concentricity over 7xD**

✓ **Eliminated vibration and chatter**



NOTE: Metric item pictured.
NOTE: Digital adjustment accuracy of 0.002 mm on diameter.

564 Balance Digital Boring Heads

Diameter Range: 50.00 mm - 65.50 mm



NOTE: Metric item pictured.
NOTE: Digital adjustment accuracy of 0.002 mm on diameter.

Form 101

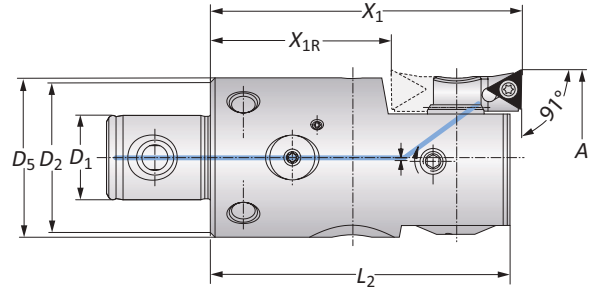

Form 20

564 Balance Digital Boring Heads

	MVS Connection	Boring Range	Boring Head				Weight	Insert Form	Part No.	
	D ₂ D ₁	A	X ₁	X _{1R}	L ₂	D ₅			Insert Holder	Boring Head
m	40 - 22	50.00 - 65.50	75.00	47.00	72.50	42.00	0.80 (kg)	20	210052	564034
	40 - 22	50.00 - 65.50	75.00	47.00	72.50	42.00	0.80 (kg)	101	210062	564034

NOTE: X_{1R} = rotated insert holder for reverse machining.
NOTE: Insert holders and inserts sold separately.

B10-M: 12-13

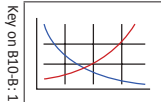

B10-F

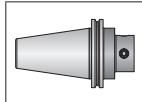

B10: VI-VII

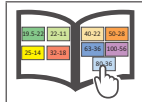

Key on B10-B: 1

m = Metric (mm)

IMPORTANT: Max spindle speed refers to maximum possible speed for an individual boring head and is not a recommended parameter. Refer to page B10-M: 12 for recommended application-specific parameters. Factory technical assistance is available for your specific applications through our Application Engineering department.
 email: engineering.eu@alliedmachine.com

564 Balance Digital Boring Heads

Alu-Line | Diameter Range: 65.00 mm - 205.00 mm



Form 101

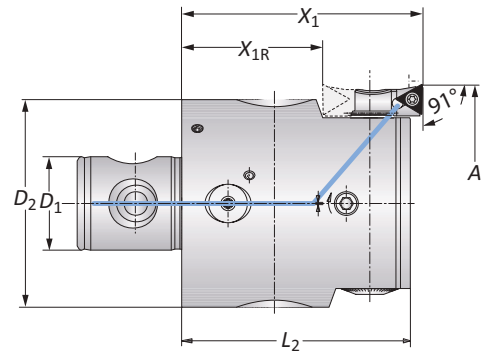
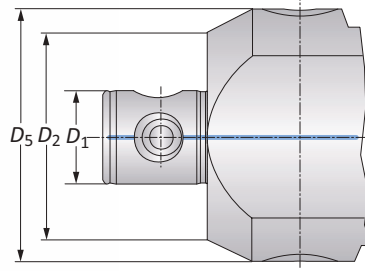

Form 20

NOTE: Metric item pictured.
NOTE: Digital adjustment accuracy of 0.002 mm on diameter.

564 Balance Digital Alu-Line Boring Heads

MVS Connection	Boring Range	Boring Head					Weight	Insert Form	Part No.	
		$D_2 D_1$	A	X_1	X_{1R}	L_2			D_5	Insert Holder
	50 - 28	65.00 - 83.00	75.00	39.00	73.00	-	0.60 (kg)	20	210020	564045
	50 - 28	65.00 - 83.00	75.00	39.00	73.00	-	0.60 (kg)	101	210063	564045
	50 - 28	65.00 - 83.00	75.00	39.00	73.00	-	0.60 (kg)	103	210064	564045
	63 - 36	82.00 - 103.00	90.00	54.00	88.00	-	1.00 (kg)	20	210020	564046
	63 - 36	82.00 - 103.00	90.00	54.00	88.00	-	1.00 (kg)	101	210063	564046
	63 - 36	82.00 - 103.00	90.00	54.00	88.00	-	1.00 (kg)	103	210064	564046
	80 - 36	100.00 - 130.00	90.00	54.00	88.00	-	1.50 (kg)	20	210020	564047
m	80 - 36	100.00 - 130.00	90.00	54.00	88.00	-	1.50 (kg)	101	210063	564047
	80 - 36	100.00 - 130.00	90.00	54.00	88.00	-	1.50 (kg)	103	210064	564047
	80 - 36	125.00 - 167.50	90.00	54.00	88.00	100.00	1.90 (kg)	20	210020	564048
	80 - 36	125.00 - 167.50	90.00	54.00	88.00	100.00	1.90 (kg)	101	210063	564048
	80 - 36	125.00 - 167.50	90.00	54.00	88.00	100.00	1.90 (kg)	103	210064	564048
	80 - 36	162.50 - 205.00	90.00	54.00	88.00	135.00	2.50 (kg)	20	210020	564049
	80 - 36	162.50 - 205.00	90.00	54.00	88.00	135.00	2.50 (kg)	101	210063	564049
	80 - 36	162.50 - 205.00	90.00	54.00	88.00	135.00	2.50 (kg)	103	210064	564049

NOTE: X_{1R} = rotated insert holder for reverse machining.
NOTE: Insert holders and inserts sold separately.

B10-M: 12-13

Key on B10-B: 1

B10-F

B10: VI-VII

m = Metric (mm)

IMPORTANT: Max spindle speed refers to maximum possible speed for an individual boring head and is not a recommended parameter. Refer to page B10-M: 12 for recommended application-specific parameters. Factory technical assistance is available for your specific applications through our Application Engineering department.
 email: engineering.eu@alliedmachine.com

Insert Holder for Abrasive Materials

Diameter Range: 65.00 mm - 205.00 mm

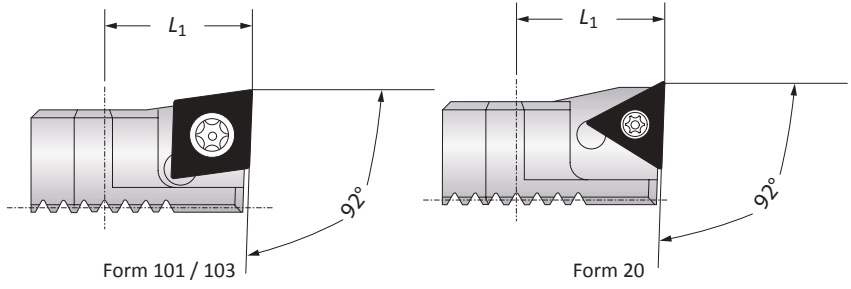

	Insert Holder				
	Boring Range	L_1	Weight	Insert Form	Part No.
m	65.00 - 205.00	18.00	0.03 (kg)	20	211061
	65.00 - 205.00	18.00	0.03 (kg)	101	211063
	65.00 - 205.00	18.00	0.03 (kg)	103	211065

NOTE: Insert holders used for abrasive materials to protect boring head against chip wash.
NOTE: When machining grey cast iron, we recommend using insert holders for abrasive materials with CBN inserts for optimised chip removal.

A
B
C
D
E
F
G
H
I
J
K
L
M
INDEX

B10-M: 12-13 B10-H B10: VI-VII

m = Metric (mm)
 Inserts sold separately

Accessories

Screws | Battery Cover | Batteries

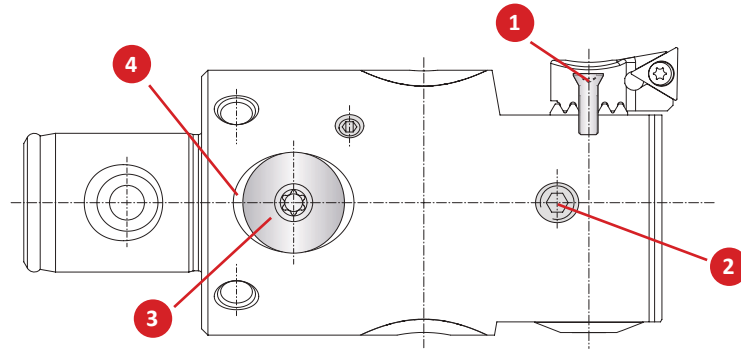

Boring Head	Part No.							
	1 Countersunk Screw	Service Key	2 Clamping Screw	Service Key	3 Battery Cover	Service Key	4 Sealing Ring	Battery*
564034	215338	T15 / H	115505	s3 / B	501016	T20 / H	415895	415896
564045	215462	T20 / H	315943	s4 / B	501016	T20 / H	415895	415896
564046	215462	T20 / H	515178	s4 / B	501016	T20 / H	415895	415896
564047	215462	T20 / H	515178	s4 / B	501016	T20 / H	415895	415896
564048	215462	T20 / H	515178	s4 / B	501016	T20 / H	415895	415896
564049	215462	T20 / H	515178	s4 / B	501016	T20 / H	415895	415896

*Replace both batteries.

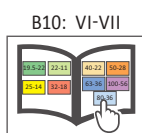
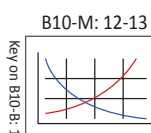

310 Analogue Product Overview

310 Analogue FINE BORING

Engineered with wear and tear in mind.

310 Wohlhaupter boring heads are made from steel for \varnothing 20.00 mm - 103.00 mm and coated Alu-Line material for \varnothing 100.00 mm - 205.00 mm boring heads to protect against corrosion and wear. The insert holder can be rotated quickly for reverse machining.

- Diameter range: 20.00 mm - 205.00 mm.
- Alu-Line diameter range: 100.00 mm - 205.00 mm.
 - Special coating on Alu-Line provides hard, durable surface.
 - Alu-Line body reduces tool weight by 50%, reducing stress on the spindle.
- Through coolant.
- Vernier diameter adjustment of 0.002 mm.
- Max cutting speed: 1,000 M/min.



IMPORTANT: Max spindle speed refers to maximum possible speed for an individual boring head and is not a recommended parameter. Refer to page B10-M: 12 for recommended application-specific parameters. Factory technical assistance is available for your specific applications through our Application Engineering department.
email: engineering.eu@alliedmachine.com

WOHLHAUPTER® 310 BORING HEAD with NOVI^{TECH}

Time is money, so make it count.

If you want to improve your machining processes, cycle time is a key factor to examine. Our customer was experiencing lengthy cycle times while machining pumps from grey cast iron. The parts required three bored holes, each with a 304.8 mm depth and a 558.8 mm reach.

In order to free up machine time, the customer questioned if their process could be more efficient. The main objectives were to decrease the current cycle time and to maintain the required surface finish to perform the burnishing process that followed.

The previous tooling ran at a slow 11.938 mm/min and a slow 84-minute cycle time to bore the three holes on each part. With our **Wohlhaupter 310 boring head** utilising the **NOVI^{TECH} vibration dampening module**, the customer increased to a more efficient 95.25 mm/min and slashed the cycle time to 10.5 minutes (an 87% decrease). Along with the increased speed, the Wohlhaupter tooling also achieved a 4 Ra finish, accomplishing everything the customer needed.

The Wohlhaupter solution reduced the process cycle time by 74 minutes. Improvements in speed and cycle time can free up machine hours, which means more throughput and higher profit for your company. **Are you losing money on applications with substantially long cycle times?**



Product:	Wohlhaupter 310 Boring Head with NOVI ^{TECH}	Measure	Competitor Boring Head	310 Boring Head w/ NOVI ^{TECH}
Objectives:	(1) Decrease cycle time (2) Maintain 4 Ra hole finish	RPM	39	469
Industry:	Oil & gas/petrochemical	Speed Rate	17.069 M/min	205.74 M/min
Part:	Pump	Feed Rate	0.305 mm/rev	0.203 mm/rev
Material:	Grey cast iron	Penetration Rate	11.938 mm/min	92.25 mm/min
Hole Ø:	139.7 mm	Cycle Time (per hole)	27 min 54 sec	3 min 32 sec
Hole Depth:	304.8 mm			

▶ Boring head
310 series
Item No. 310008

▶ NOVI^{TECH}
vibration dampening
intermediate module
Item No. 519005



The Wohlhaupter 310 boring head with the NOVI^{TECH} vibration dampening module provided:

✓ Increased penetration rate

✓ Decreased cycle time

74 minute
cycle time reduction

310 Analogue Boring Heads

Diameter Range: 20.00 mm - 103.00 mm

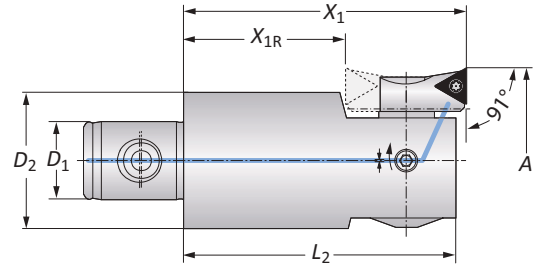
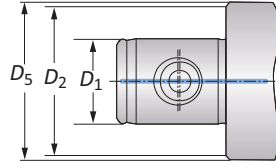

Form 101 / 103

Form 20

310 Analogue Boring Heads

MVS Connection	Boring Range	Boring Head					Weight	Insert Form	Part No.	
		D_2 D_1	A	X_1	X_{1R}	L_2			D_5	Insert Holder
	19 - 11	20.00 - 24.50	46.00	-	43.00	-	0.10 (kg)	20*	364077	310010
	22 - 11	24.50 - 29.50	46.00	-	43.50	23.00	0.15 (kg)	20	210059	310020
	22 - 11	24.50 - 29.50	46.00	-	43.50	23.00	0.15 (kg)	101	210069	310020
	25 - 14	29.00 - 37.00	56.00	-	53.50	26.00	0.20 (kg)	20	210059	310001
	25 - 14	29.00 - 37.00	56.00	-	53.50	26.00	0.20 (kg)	101	210069	310001
	25 - 14	36.00 - 44.00	56.00	28.00	53.50	26.00	0.20 (kg)	20	210052	310001
	25 - 14	36.00 - 44.00	56.00	28.00	53.50	26.00	0.20 (kg)	101	210062	310001
	32 - 18	43.00 - 54.00	66.00	38.00	63.50	-	0.40 (kg)	20	210052	310003
	32 - 18	43.00 - 54.00	66.00	38.00	63.50	-	0.40 (kg)	101	210062	310003
m	40 - 22	53.00 - 66.00	75.00	39.00	72.50	-	0.70 (kg)	20	210020	310004
	40 - 22	53.00 - 66.00	75.00	39.00	72.50	-	0.70 (kg)	101	210063	310004
	40 - 22	53.00 - 66.00	75.00	39.00	72.50	-	0.70 (kg)	103	210064	310004
	50 - 28	65.00 - 83.00	75.00	39.00	72.50	-	1.20 (kg)	20	210020	310005
	50 - 28	65.00 - 83.00	75.00	39.00	72.50	-	1.20 (kg)	101	210063	310005
	50 - 28	65.00 - 83.00	75.00	39.00	72.50	-	1.20 (kg)	103	210064	310005
	63 - 36	82.00 - 103.00	90.00	54.00	87.50	-	2.20 (kg)	20	210020	310006
	63 - 36	82.00 - 103.00	90.00	54.00	87.50	-	2.20 (kg)	101	210063	310006
	63 - 36	82.00 - 103.00	90.00	54.00	87.50	-	2.20 (kg)	103	210064	310006

*Not suitable for indexable inserts with a radius of 0.80 mm.

NOTE: X_{1R} = rotated insert holder for reverse machining.

NOTE: Insert holders and inserts sold separately.

B10-M: 12-13

B10-F

B10: VI-VII

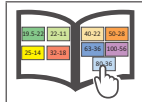
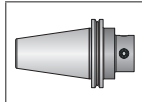
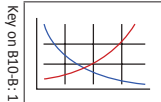

m = Metric (mm)

IMPORTANT: Max spindle speed refers to maximum possible speed for an individual boring head and is not a recommended parameter. Refer to page B10-M: 12 for recommended application-specific parameters. Factory technical assistance is available for your specific applications through our Application Engineering department.
email: engineering.eu@alliedmachine.com

310 Analogue Boring Heads

Alu-Line | Diameter Range: 100.00 mm - 205.00 mm



Form 101 / 103

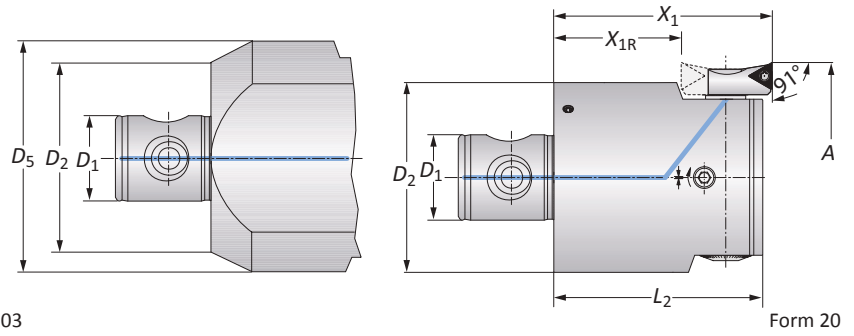

Form 20

310 Analogue Alu-Line Boring Heads

MVS Connection	Boring Range	Boring Head					Weight	Insert Form	Part No.	
		$D_2 D_1$	A	X_1	X_{1R}	L_2			D_5	Insert Holder
	80 - 36	100.00 - 130.00	90.00	54.00	87.50	-	1.40 (kg)	20	210020	310007
	80 - 36	100.00 - 130.00	90.00	54.00	87.50	-	1.40 (kg)	101	210063	310007
	80 - 36	100.00 - 130.00	90.00	54.00	87.50	-	1.40 (kg)	103	210064	310007
	80 - 36	125.00 - 167.50	90.00	54.00	87.50	100.00	1.80 (kg)	20	210020	310008
	80 - 36	125.00 - 167.50	90.00	54.00	87.50	100.00	1.80 (kg)	101	210063	310008
	80 - 36	125.00 - 167.50	90.00	54.00	87.50	100.00	1.80 (kg)	103	210064	310008
	80 - 36	162.50 - 205.00	90.00	54.00	87.50	135.00	2.40 (kg)	20	210020	310009
	80 - 36	162.50 - 205.00	90.00	54.00	87.50	135.00	2.40 (kg)	101	210063	310009
	80 - 36	162.50 - 205.00	90.00	54.00	87.50	135.00	2.40 (kg)	103	210064	310009

NOTE: X_{1R} = rotated insert holder for reverse machining.

NOTE: Insert holders and inserts sold separately.

B10-M: 12-13

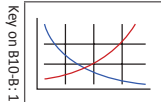

B10-F

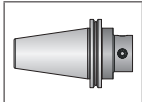

B10: VI-VII

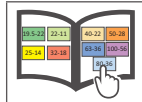

 = Metric (mm)

IMPORTANT: Max spindle speed refers to maximum possible speed for an individual boring head and is not a recommended parameter. Refer to page B10-M: 12 for recommended application-specific parameters. Factory technical assistance is available for your specific applications through our Application Engineering department.
 email: engineering.eu@alliedmachine.com

Insert Holders for Abrasive Materials | Serrated Shims

Diameter Range: 53.00 mm - 205.00 mm

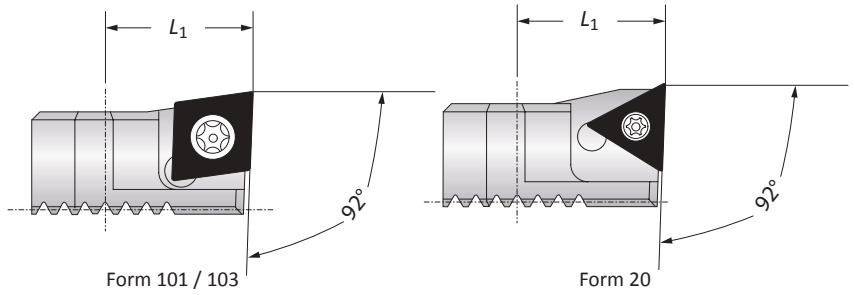

Insert Holders

	Boring Range	Insert Holder L_1	Weight	Insert Form	Part No.
m	53.00 - 205.00	18.00	0.03 (kg)	20	211061
	53.00 - 205.00	18.00	0.03 (kg)	101	211063
	53.00 - 205.00	18.00	0.03 (kg)	103	211065

NOTE: Insert holders used for abrasive materials to protect boring head against chip wash.

NOTE: When machining grey cast iron, we recommend using insert holders for abrasive materials with CBN inserts for optimised chip removal.

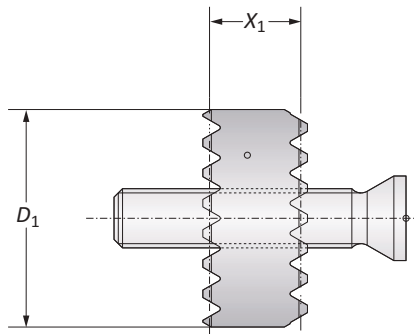

Serrated Shims

	Boring Range	Additional Boring Range	Serrated Shim		Weight	Part No.	
			X_1	D_1		Serrated Shim & Screw	Replacement Screw
m	29.00 - 54.00	8.00	4.00	12.00	0.01 (kg)	310070	415360
	29.00 - 54.00	12.00	6.00	12.00	0.01 (kg)	310071	415342
	53.00 - 205.00	10.00	5.00	18.00	0.01 (kg)	310074	515595
	53.00 - 205.00	15.00	7.50	18.00	0.01 (kg)	310075	515596

B10-M: 12-13 | B10-H | B10: VI-VII

m = Metric (mm)
Inserts sold separately

Accessories

Screws

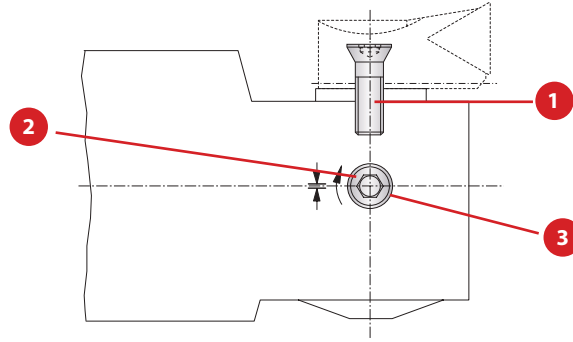

Boring Head	1 Countersunk Screw		2 Clamping Screw		3 Ball
	Part No.	Service Key	Part No.	Service Key	Part No.
310010	215323	T15 / H	364260	s2.0 / A	364270
310020	215338	T15 / H	364138	s2.5 / A	364139
310001	215338	T15 / H	115136	s2.5 / A	-
310003	215338	T15 / H	115180	s2.5 / A	-
310004	215462	T20 / H	115249	s4 / B	-
310005	215462	T20 / H	115185	s4 / B	-
310006	215462	T20 / H	315279	s4 / B	-
310007	215462	T20 / H	115186	s4 / B	-
310008	215462	T20 / H	115186	s4 / B	-
310009	215462	T20 / H	115186	s4 / B	-

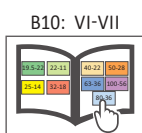
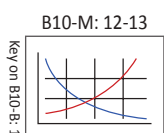

537 Product Overview



537 Cassettes FINE BORING

Engineered for easy precision.

537 fine boring cassettes offer high accuracy and are available in an easy-to-use digital or analogue version. The digital version features a docking port to attach the 3E^{TECH+} digital readout module for μ -accurate diameter adjustments while the Analogue cassettes provide highly accurate adjustments through the vernier scale. 537 cassettes are made of hardened steel and can be used on serrated tool bodies and slides from 100.00 mm - 3255.00 mm. The insert holder can be rotated easily for reverse machining applications.

Experience **digital precision boring** for yourself.

- Diameter range: 100.00 mm - 205.00 mm.
- Cassette can be used on large diameter serrated slides (**pg. B10-G: 8**): 200.00 mm - 3255.00 mm.
- Through coolant.
- 3E^{TECH+} module provides a simple digital readout.
- Analogue version with a vernier scale.
- Max cutting speed: 900 M/min.



NOTE: 3E^{TECH+} adjustment accuracy of 0.001 mm on diameter.

NOTE: Vernier adjustment accuracy of 0.002 mm on diameter.

IMPORTANT: Max spindle speed refers to maximum possible speed for an individual boring head and is not a recommended parameter. Refer to page B10-M: 12 for recommended application-specific parameters. Factory technical assistance is available for your specific applications through our Application Engineering department.
email: engineering.eu@alliedmachine.com

537 BORING CASSETTES



NEW vernier scale
on both analogue
and digital cassettes

NEW digital 537
cassettes with 3E^{TECH+}
docking port

- ✓ Convenient tool handling
- ✓ Large range of applications
- ✓ Hardened steel bodies

537 Analogue Cassettes

Diameter Range: 100.00 mm - 205.00 mm



Form 101 / 103

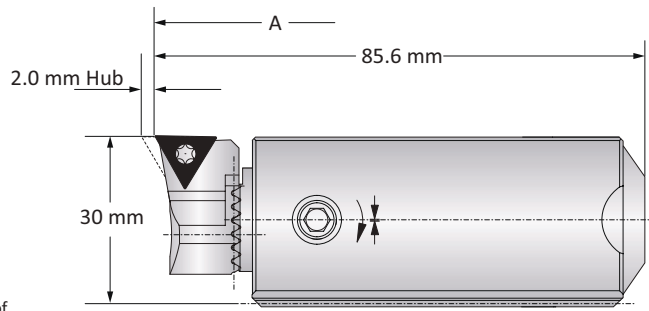

Form 20

NOTE: Vernier adjustment accuracy of 0.0001" or 0.002 mm on diameter.

Analogue 537 Cassettes

	Boring Range	Weight	Insert Form	Part No.		
				Insert Holder	Clamping Piece	Cassette*
m	100.00 - 205.00	0.60 (kg)	20	210020	137026	537051
	100.00 - 205.00	0.60 (kg)	101	210063	137026	537051
	100.00 - 205.00	0.60 (kg)	103	210064	137026	537051

*Required serrated tool body sold separately.

NOTE: Cassette and insert holder can be used on large diameter serrated slides (B10-G: 10 - 11).

NOTE: Insert holders, inserts, and clamping pieces *sold separately*.

B10-M: 12-13

B10-F

B10: VI-VII

Key on B10-B: 1

m = Metric (mm)

IMPORTANT: Max spindle speed refers to maximum possible speed for an individual boring head and is not a recommended parameter. Refer to page B10-M: 12 for recommended application-specific parameters. Factory technical assistance is available for your specific applications through our Application Engineering department.
 email: engineering.eu@alliedmachine.com

537 Digital 3E^{TECH+} Cassettes

Diameter Range: 100.00 mm - 205.00 mm



Form 101 / 103

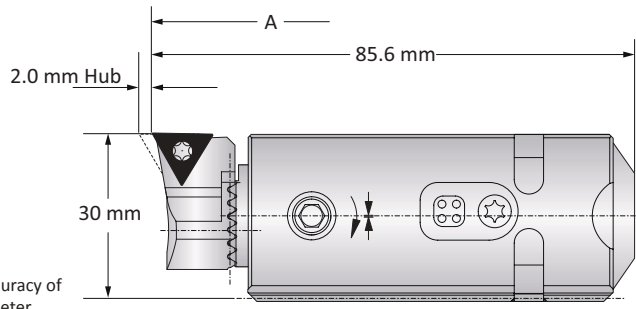

Form 20

NOTE: Vernier adjustment accuracy of 0.0001" or 0.002 mm on diameter.

537 Digital 3E^{TECH+} Cassettes

	Boring Range	Weight	Insert Form	Part No.		
				Insert Holder	Clamping Piece	Cassette*
	100.00 - 205.00	0.60 (kg)	20	210020	137026	537052
	100.00 - 205.00	0.60 (kg)	101	210063	137026	537052
	100.00 - 205.00	0.60 (kg)	103	210064	137026	537052

*Required serrated tool body sold separately.

NOTE: Cassette and insert holder can be used on large diameter serrated slides (B10-G: 10 - 11).

NOTE: 3E^{TECH+} digital readout module, charging unit, insert holders, inserts, and clamping pieces **sold separately**.

3E^{TECH+} Digital Readout Module

Part No.	Charging Unit*
536015	536016

NOTE: WEEE-Reg.-Nr. DE 15820388

*Charging unit sold separately.



NOTE: 3E^{TECH+} adjustment accuracy of 0.001 mm on diameter.

B10-M: 12-13

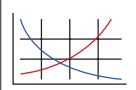

Key on B10-B: 1

B10-F

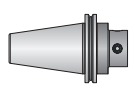

B10: VI-VII

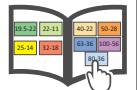

 = Metric (mm)

IMPORTANT: Max spindle speed refers to maximum possible speed for an individual boring head and is not a recommended parameter. Refer to page B10-M: 12 for recommended application-specific parameters. Factory technical assistance is available for your specific applications through our Application Engineering department.
 email: engineering.eu@alliedmachine.com

Serrated Tool Bodies | Insert Holders for Abrasive Materials

Diameter Range: 100.00 mm - 205.00 mm

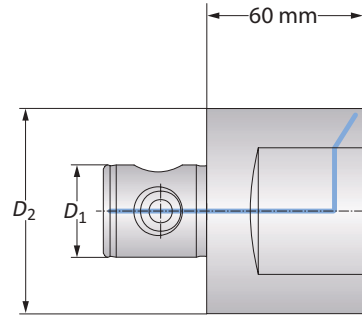

Serrated Tool Bodies

MVS Connection		Serrated Tool Body	
	D_2 D_1	Boring Range	Part No.
m	80 - 36	100.00 - 155.00	148007
	80 - 36	150.00 - 205.00	148009

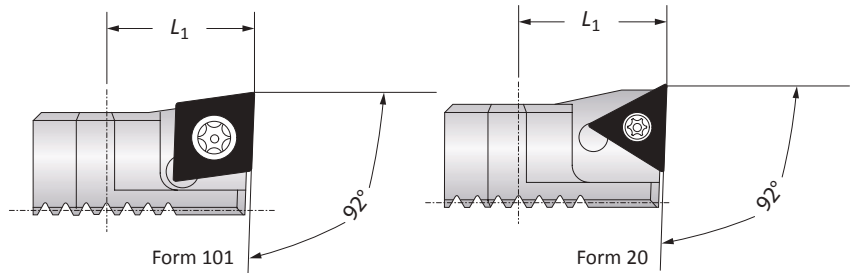

Insert Holders for Abrasive Materials

		Insert Holder			
	Boring Range	L_1	Weight	Insert Form	Part No.
m	100.00 - 205.00	18.00	0.03 (kg)	20	211061
	100.00 - 205.00	18.00	0.03 (kg)	101	211063
	100.00 - 205.00	18.00	0.03 (kg)	103	211065

NOTE: Insert holders used for abrasive materials to protect boring head against chip wash.

NOTE: When machining grey cast iron, we recommend using insert holders for abrasive materials with CBN inserts for optimised chip removal.

B10-M: 12-13

B10-H

B10: VI-VII

537 Accessories | 3E^{TECH+} Accessories | Clamping Pieces

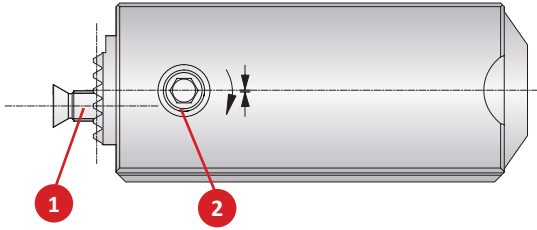

537 Analogue Cassette

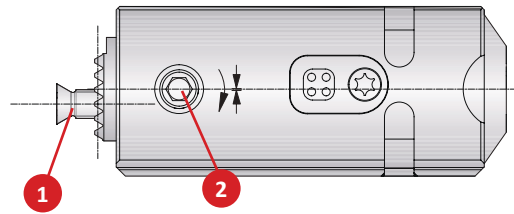

537 3E^{TECH+} Cassette

537 Accessories

Cassette Part No.	1 Countersunk Screw		2 Clamping Screw	
	Part No.	Service Key	Part No.	Service Key
537051	215462	T20 / H	115249	s4 / F
537052	215462	T20 / H	315789	s4 / F

3E^{TECH+} Accessories

1
Charging Unit
Part No.
536016



NOTE: Charging unit sold separately from 3E^{TECH+}

NOTE: 3E^{TECH+} adjustment accuracy of 0.00005" or 0.001 mm on diameter

3E^{TECH} Accessories (Old Display)

1	2
Sealing Ring	Battery CR2032
Part No.	Part No.
215483	515491

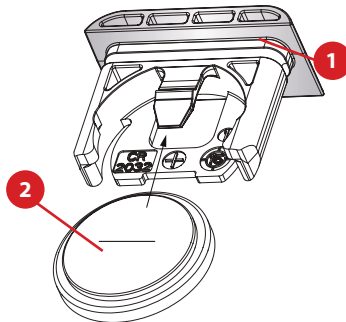

NOTE: Not required for 3E^{TECH+} (new display)

537 Clamping Pieces

Slide Type	Complete Part No.	Service Key		Replacement Components		
				1 Cap Screw	2 Clamping Nut	3 Disk Spring
Serrated Tool Bodies	137026	115578	s6 / B	215101	140118	337105
Basic and Eco Slides	137027			215102	215105	337105
Flex Slides	137019			415900	215105	337105

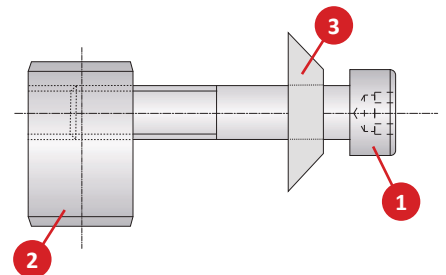

NOTE: Clamping pieces sold separately

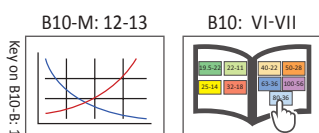

 = Metric (mm)
Inserts sold separately

Guaranteed Test / Demo Application Form

Distributor PO #	
------------------	--

The following must be filled out completely before your test will be considered

IMPORTANT: For processing, send purchase order to your Allied Field Sales Engineer (FSE). Please clearly mark the paperwork as "Test Order."

Distributor Information

Company Name: _____
 Contact: _____
 Account Number: _____
 Phone: _____
 Email: _____

End User Information

Company Name: _____
 Contact: _____
 Industry: _____
 Phone: _____
 Email: _____

Current Process

List all tooling, coatings, substrates, speeds and feeds, tool life, and any problems you are experiencing

Test Objective

List what would make this a successful test (i.e. penetration rate, finish, tool life, hole size, etc.)

Application Information

Hole Diameter: _____ in/mm	Tolerance: _____	Material: _____ (4150, A36, cast iron, etc.)
Pre-existing Diameter: _____ in/mm	Depth of Cut: _____ in/mm	Hardness: _____ (BHN, Rc)
Required Finish: _____ RMS		State: _____ (Casting, hot rolled, forging)

Machine Information

Machine Type: _____ (Lathe, screw machine, machine center, etc.)	Builder: _____ (Haas, Mori Seiki, etc.)	Model #: _____
Shank Required: _____ (CAT50, Morse taper, etc.)		Power: _____ HP/KW
Rigidity: _____	Orientation: _____	Tool Rotating: _____
<input type="checkbox"/> Excellent	<input type="checkbox"/> Vertical	<input type="checkbox"/> Yes
<input type="checkbox"/> Good	<input type="checkbox"/> Horizontal	<input type="checkbox"/> No
<input type="checkbox"/> Poor		Thrust: _____ lbs/N

Coolant Information

Coolant Delivery: _____ (Through tool, flood)	Coolant Pressure: _____ PSI / bar
Coolant Type: _____ (Air mist, oil, synthetic, water soluble, etc.)	Coolant Volume: _____ GPM / LPM

Requested Tooling

QTY	Item Number

QTY	Item Number

engineering.eu@alliedmachine.com

Allied Machine & Engineering Co. (Europe) Ltd
 93 Vantage Point, Pensnett Estate,
 Kingswinford, DY6 7FR, United Kingdom

+44 (0)1384 400 900
www.alliedmachine.com



ALLIED MACHINE & ENGINEERING



WOHLHAUPTER
 Holmaking Solutions for Today's Manufacturing

Warranty Information



Allied Machine & Engineering (“Allied Machine”) warrants to original equipment manufacturers, distributors, industrial and commercial users of its products for one year from the original date of sale that each new product manufactured or supplied by Allied Machine shall be free from defects in material and workmanship.

Allied Machine’s sole and exclusive obligation under this warranty is limited to, at its option, without additional charge, replacing or repairing this product or issuing a credit. For this warranty to be applied, the product must be returned freight prepaid to the plant designated by an Allied Machine representative and which, upon inspection, is determined by Allied Machine to be defective in material and workmanship.

Complete information as to operating conditions, machine, setup, and the application of cutting fluid should accompany any product returned for inspection. This warranty shall not apply to any Allied Machine products which have been subjected to misuse, abuse, improper operating conditions, improper machine setup or improper application of cutting fluid or which have been repaired or altered if such repair or alteration, in the judgement of Allied Machine, would adversely affect the performance of the product.

THIS WARRANTY IS IN LIEU OF ALL OTHER WARRANTIES, EXPRESS OR IMPLIED, INCLUDING ANY IMPLIED WARRANTY OF MERCHANTABILITY OR FITNESS FOR A PARTICULAR PURPOSE. Allied Machine shall have no liability or responsibility for any claim, whether in contract, tort or otherwise, for any loss or damage arising out of, connected with, or resulting from the manufacture, sale, delivery or use of any product sold hereunder, in excess of the cost of replacement or repair as provided herein.

Allied Machine shall not be liable in contract or in tort (including, without limitation, negligence, strict liability or otherwise) for economic losses of any kind or for any special, incidental, indirect, consequential, punitive or exemplary damages arising in any way out of the performance of, or failure to perform this agreement.

ALL PRICES, DELIVERIES, DESIGNS, AND MATERIALS ARE SUBJECT TO CHANGE WITHOUT NOTICE.



Allied Machine & Engineering Co. Europe Ltd. is registered to ISO 9001:2015 by bsi.



Allied Machine & Engineering is registered to ISO 9001:2015 by DQS.



Wohlhaupter GmbH is registered to ISO 9001:2015 by QUACERT.

Europe

Allied Machine & Engineering Co. (Europe) Ltd.

93 Vantage Point
Pensnett Estate
Kingswinford
West Midlands
DY6 7FR England

Phone:

+44 (0) 1384 400900

Wohlhaupter® GmbH

Maybachstrasse 4
Postfach 1264
72636 Frickenhausen
Germany

Phone:

+49 (0) 7022 408.0

United States

Allied Machine & Engineering

120 Deeds Drive
Dover OH 44622
United States

Phone:

+1.330.343.4283

Toll Free USA and Canada:

800.321.5537

Toll Free USA and Canada:

800.223.5140

Allied Machine & Engineering

485 W Third Street
Dover OH 44622
United States

Phone:

+1.330.343.4283

Toll Free USA and Canada:

800.321.5537

Asia

Wohlhaupter® India Pvt. Ltd.

B-23, 3rd Floor
B Block Community Centre
Janakpuri, New Delhi - 110058
India

Phone:

+91 (0) 11.41827044

Your local Allied Machine representative:

www.alliedmachine.com

Allied Machine & Engineering Co. Europe Ltd. is registered to **ISO 9001:2015** by bsi.

Allied Machine & Engineering is registered to **ISO 9001:2015** by DQS.

Wohlhaupter GmbH is registered to **ISO 9001:2015** by QUACERT.

